

专注真空泵与真空系统研发制造16年  
Vacuum Pumps and Vacuum Systems

普诺克真空科技(香港)有限公司  
东莞市普诺克真空科技有限公司

亚洲总部: 香港新界葵涌葵昌路26-38號豪華工业大厦

广东地址: 广东省东莞市南城区高盛科技园北区

电 话: +86 (0769) 8978 4003

传 真: +86 (0769) 2202 6929

邮 箱: sales@pronotek.com

[www.pronotek.com](http://www.pronotek.com)

# PRONOTEK VACUUM PUMPS



PRONOTEK  
VACUUM PUMPS & VACUUM SYSTEMS

意大利品牌





专注真空泵与真空系统研发制造16年

# 普诺克

意大利纯正血统  
全球领先真空泵的制造厂商

Pronotek真空泵及真空系统是全球领先的真空泵的制造厂商之一。我们的产品系列涵盖了广泛应用于所有工业领域的真空技术解决方案。

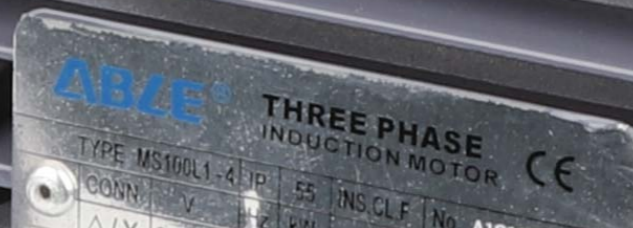

ALFONSO  
PIANTEDOSI

Firmato da:  
marchi\_disegni  
Roma, 13 maggio



Ministero dello Sviluppo Economico

Direzione generale per la lotta alla contraffazione

Ufficio Italiano Brevetti e Marchi

## Attestato di registrazione per Marchio di Impresa

Primo Deposito

Il presente attestato viene rilasciato per il marchio di impresa oggetto della domanda

Numero deposito/Numero  
registrazione: 302018000027813

Titolare: • DONGGUAN PRONOTEK  
VACUUM TECHNOLOGY  
CO., LTD. 100.0%

Data deposito: 21/08/2018

Mandatario/Rappresentante: Amelia Forattini

Indirizzo: Internazionale Brevetti  
piazza Castello 1 20121 Milano

Titolo del marchio: PRONOTEK

Immagine del marchio

# PRONOTEK

### Classi

- Classe 7 - declaratoria: Macchine e macchine-utensili; motori (eccetto quelli per veicoli terrestri); giunti e organi di trasmissione (eccetto quelli per veicoli terrestri); strumenti agricoli tranne quelli azionati manualmente; incubatrici per uova; distributori automatici.

#### Prodotti/servizi oggetto di protezione:

- 70241: macchine motrici, diverse da quelle per veicoli terrestri
- 70205: pompe di lubrificazione
- 70312: pompe per vuoto [macchine]
- 70473: comandi pneumatici per macchine e motori
- 70534: macchine per soffiatura
- 888888: pompe a vite
- 70317: regolatori di pressione [parti di macchine]
- 70457: filtri [parti di macchine o di motori]
- 888888: macchine e apparati pneumatici
- 70392: macchine ad aria compressa
- 70393: pompe ad aria compressa
- 70310: pompe ad aria [installazioni di garages]
- 70152: disolatori di vapore
- filtri d'aria per motori di automobile
- filtri dell'olio per motori

## 中国香港

真空泵与真空系统研发中心



### 关于普诺克

Pronotek真空泵及真空系统是全球领先的真空泵的制造厂商之一。我们的产品系列涵盖了广泛应用于所有工业领域的真空技术解决方案。

凭借在真空泵及真空系统制造领域近30多年的经验，Pronotek可提供种类齐全的各类真空泵和真空系统，为全球提供最广泛的工业真空技术。

Pronotek Vacuum创建于1988年，总部位于意大利博洛尼亚（Bologna），业务范围遍及全球20多个国家/地区，并在全球10多个国家有销售代理商，可以现场为客户提供真空技术支持和定制真空解决方案。

2017年，普诺克真空落户中国，并着力开拓中国市场，在中国香港成立亚太地区销售总部【普诺克真空科技（香港）有限公司】。

我们的所有的真空产品都拥有丰富的选项和先进的设计特点，可满足各种不同的应用需求，以最合适、最具成本效益的解决方案使客户获取利益。我们不断进行自我评估确保始终保持最高水平，并持续开发创新技术，为真空系统应用的未来发展树立标杆。

Pronotek主要产品包括：旋片式真空泵、罗茨泵、干式螺杆泵、扩散泵、分子泵、低温泵、真空系统、定制化真空系统、真空仪表、氦质谱检漏仪、真空阀门及连接件等。

在您的真空应用领域，我们能够满足您的每一次需求。对于一些特殊要求，我们的专业技术团队将会为您提供合理化的真空解决方案。目前我们的产品已经应用于工业领域的各个行业：半导体、平板显示器、LED 和太阳能电池的制造、电力、玻璃和其他涂层应用、钢和其他冶金、制药和化学、真空包装和干燥等。

普诺克真空将进一步发展中国市场，通过创新的工业解决方案，不断扩大在中国的市场占有率，为中国客户持续提供可持续的生产力。

# 单级旋片式真空泵

可靠耐用，适合粗真空和中真空应用

SINGLE STAGE OIL SEALED ROTARY VANE PUMPS

PNK SP SERIES



## 特性和优点

PRONOTEK单级旋片泵是长期以来在低真空和高真空领域工艺中最为普及的产品。这种泵的优异特性包括使用寿命长、抽吸能力不受气体类型影响。SP系列的抽吸能力为 20 到 630 m<sup>3</sup>/h，几乎覆盖了工业和涂层技术中的所有应用领域。适用于更广泛的工业应用，具有良好的水蒸汽处理能力用户可进行现场维修 - 更高的生产效率 更换油和过滤器十分方便 - 易于维护比大多数类似的单级旋转式叶片泵更安静最小的油排放并且十分环保内置 ISO 和 BSP 连接 - 易于集成 SP系列旋片泵拥有全套组装机包 - 适合多种性能要求，简单方便。

### ■ 可靠性

可靠且稳定的制程 - 即使是在高气体负荷下也可提供有效的润滑

### ■ 稳定

无制程污染 - 油和空气反吸保护

### ■ 性能

长期无故障 - 传动轴杆上安装有工业级滚柱轴承

### ■ 再保证

安心 - 经过多年尝试、测试，已经成为工业标准

可靠且稳定 - 高真空性能

## 应用领域

■ 真空冶金加工

■ 薄膜覆层技术

■ 制药冷冻干燥

■ 冷冻和空调系统抽空、干燥和回填

# 单级旋片式真空泵

## SINGLE STAGE - ROTARY VACUUM PUMP

### 规格参数

	50/60HZ	PNK SP 0020	PNK SP 0025	PNK SP 0040
额定流量 Ultimate pressure	m <sup>3</sup> /h	20	25	40
		25	30	48
极限真空 Ultimate pressure	mbar(abs)	0.5	0.5	0.1
口径 Diameter		G3/4	G3/4	G 1 ¼" / G 1 ¼"
电机功率 Mptor power	KW	0.75	0.75	1.1
电压 Voltage	V	220-240/380-415	220-240/380-415	220-240/345-415
		220-280/380-440	220-280/380-440	220-275/380-480
电流 Current	A	3.0/1.75	3.0/1.75	5.0/2.9
		3.6/2.1	3.6/2.1	5.4/3.1
转速 Nominal speed	min	3000/3600	3000/3600	1400/1720
噪音 Sound	dB(A)	62	62	64
油量 Oil	L	0.5	0.5	1.5
重量(未注油) Weight	kg	19	19	42

	50/60HZ	PNK SP 0063	PNK SP 0100	PNK SP 0160
额定流量 Ultimate pressure	m <sup>3</sup> /h	63	100	160
		78	120	190
极限真空 Ultimate pressure	mbar(abs)	0.1	0.1	0.1
口径 Diameter		G 1 ¼" / G 1 ¼"	G 1 ¼" / G 1 ¼"	G 2" / G 2"
电机功率 Mptor power	KW	2.2	3	5.5kw
电压 Voltage	V	220-240/345-415	220-240/345-415	345-415/600-720
		220-275/380-480	220-275/380-480	380-480/660-720
电流 Current	A	8.5/4.9	11.8/6.8	9.0/5.2
		9.2/5.3	13.0/7.5	9.4/5.2
转速 Nominal speed	min	1405/1720	1405/1720	1455/1720
噪音 Sound	dB(A)	63	65	67
油量 Oil	L	2	2	6
重量(未注油) Weight	kg	55	75	149

# 单级旋片式真空泵

## SINGLE STAGE - ROTARY VACUUM PUMP

### 规格参数

	50/60HZ	PNK SP 0200	PNK SP 0250	PNK SP 0300
额定流量 Ultimate pressure	m <sup>3</sup> /h	200	250	300
		240	300	360
极限真空 Ultimate pressure	mbar(abs)	0.1	0.1	0.1
口径 Diameter		G 2" / G 2"	G 2" / G 2"	G 2" / G 2"
电机功率 Mptor power	KW	5.5	7.5	7.5
电压 Voltage	V	345-415/600-720	345-415/600-720	345-415/600-720
		380-480/660-720	380-480/660-720	380-480/660-720
电流 Current	A	9.0/5.2	16.7/7.6	16.7/7.6
		9.4/5.2	17.3/11.0	17.3/11.0
转速 Nominal speed	min	1455/1720	1455/1720	1455/1720
噪音 Sound	dB(A)	67	72	72
油量 Oil	L	6	8	8
重量(未注油) Weight	kg	149	193	193

	50/60HZ	PNK SP 0630	PNK SP 0750
额定流量 Ultimate pressure	m <sup>3</sup> /h	630	750
		755	120
极限真空 Ultimate pressure	mbar(abs)	0.1	0.1
口径 Diameter		G4"	G4"
电机功率 Mptor power	KW	15.0	18.5kw
电压 Voltage	V	345-415/600-720	220-240/345-415
		220-275/380-480	220-275/380-480
电流 Current	A	32.5/18.8	39.2/22.8
		33.7/18.9	40.3/23.9
转速 Nominal speed	min	1455/1720	1405/1720
噪音 Sound	dB(A)	75	76
油量 Oil	L	35	35
重量(未注油) Weight	kg	630	640

# 单级旋片式真空泵

## SINGLE STAGE - ROTARY VACUUM PUMP

### 性能曲线

PNK SP 0020

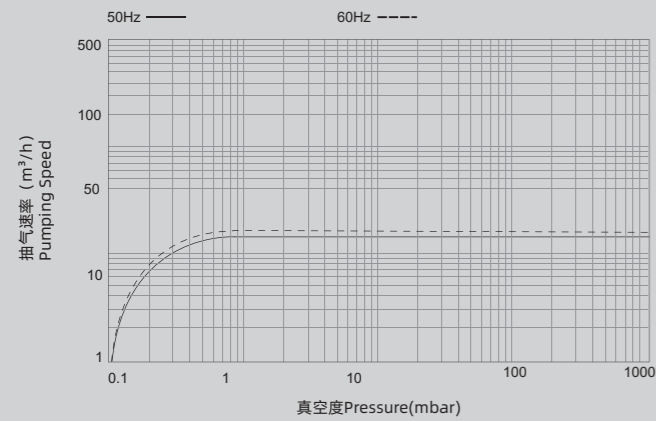

PNK SP0 0025

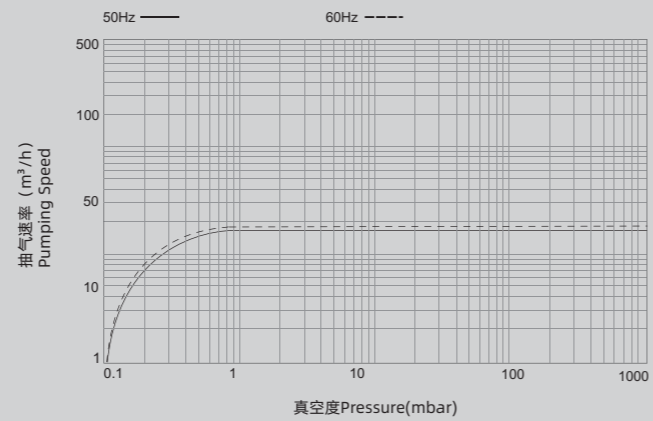

PNK SP 0100

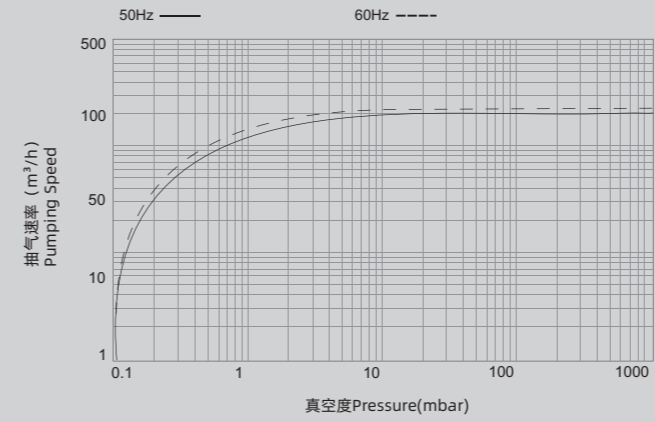

PNK SP 0160

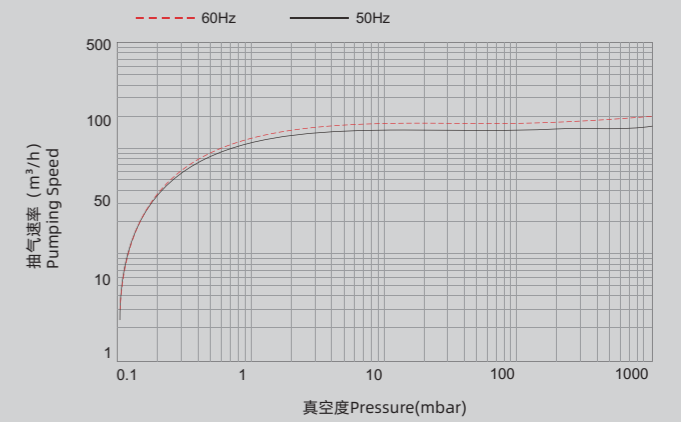

PNK SP 0040

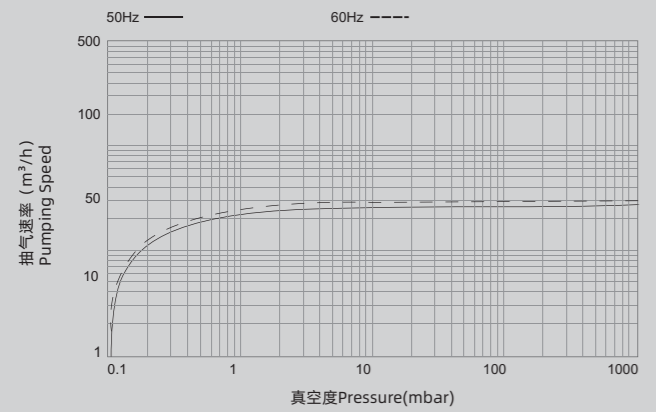

PNK SP 0063

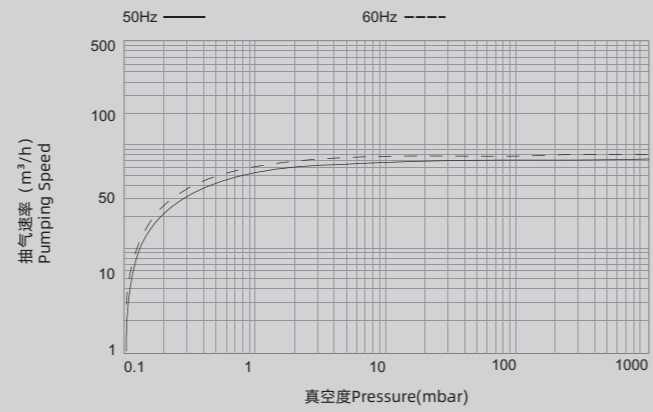

PNK SP 0200

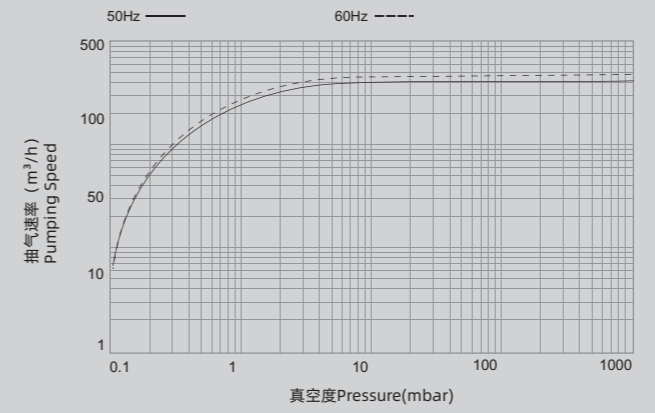

PNK SP0 250

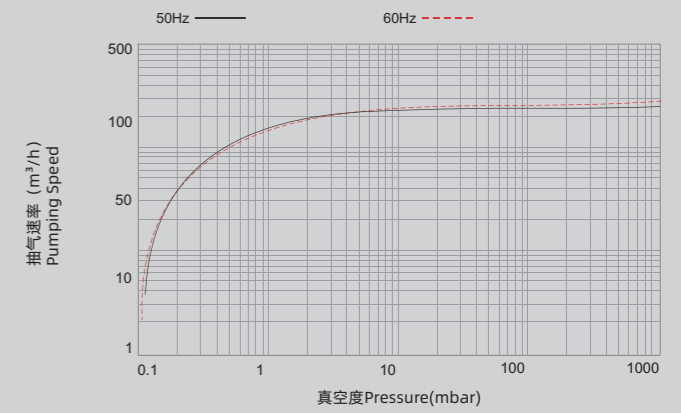

PNK SP 0300

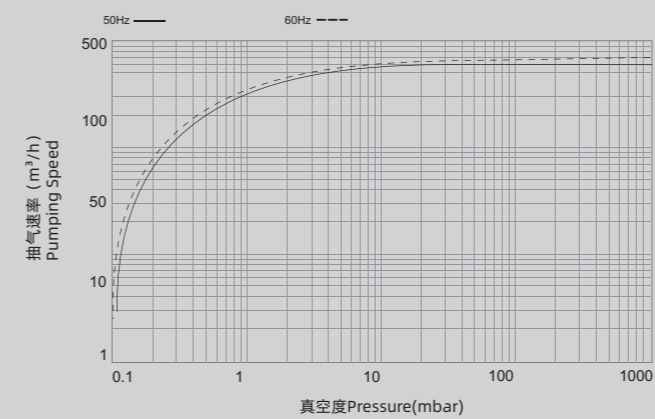



# 单级旋片式真空泵

## SINGLE STAGE - ROTARY VACUUM PUMP

### 安装尺寸图

PNK SP 0020

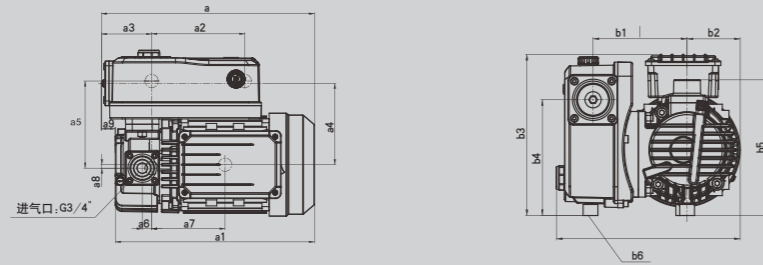

TYPE	a	a1	a2	a3	a4	a5	a6	a7	a8	a9	b	b1	b2	b3	b4	b5	b6
PNK SP 0020	320	229	140	75.5	122.3	131	14	101.5	5.3	21	249	127.5	72	219	157	184	M6

PNK SP 0025

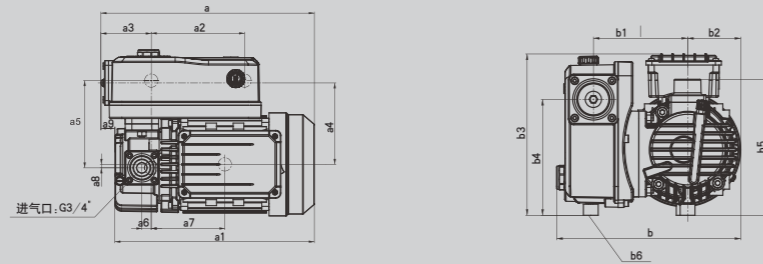

TYPE	a	a1	a2	a3	a4	a5	a6	a7	a8	a9	b	b1	b2	b3	b4	b5	b6
PNK SP 0025	320	229	140	75.5	122.3	131	14	101.5	5.3	21	249	127.5	72	219	157	184	M6

PNK SP 0040

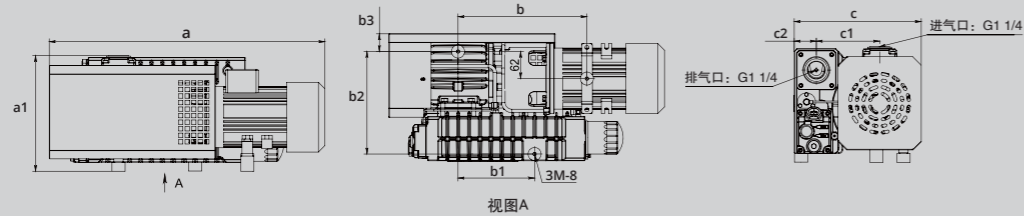

TYPE	a	a1	b	b1	b2	b3	c	c1	c2
PNK SP 0040	632	265	295	175.5	235	40.5	291	145	50.5

PNK SP 0063

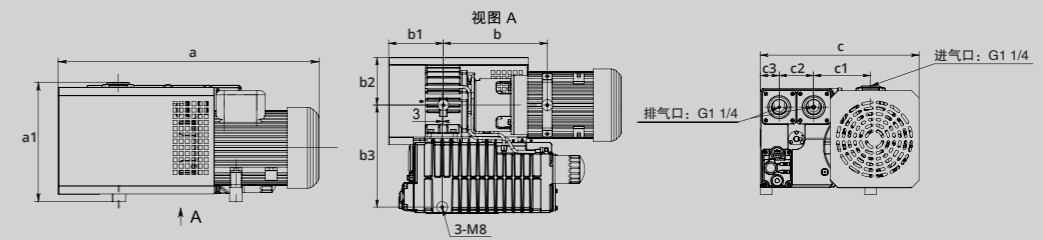

TYPE	a	a1	b	b1	b2	b3	c	c1	c2	c3
PNK SP 0063	625	288	280	144	128	275.5	419	150.5	91	49.5

PNK SP 0100

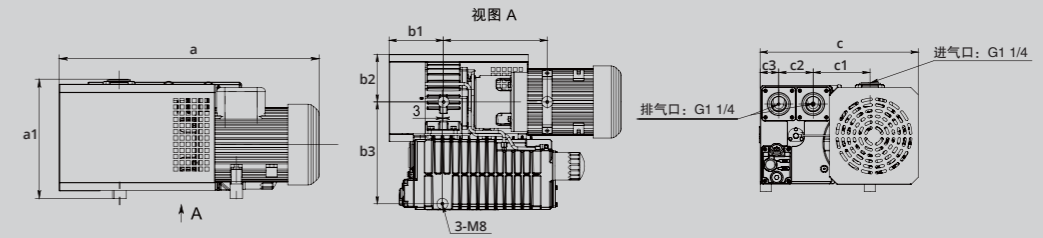

TYPE	a	a1	b	b1	b2	b3	c	c1	c2	c3
PNK SP 0100	681	298	307	174	127.5	276	419	151	91	49.5

PNK SP 0160

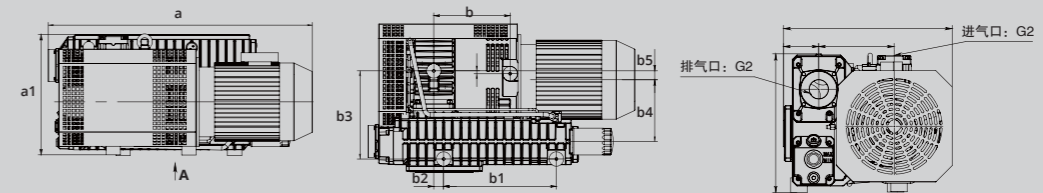

TYPE	a	a1	b	b1	b2	b3	b4	b5	c	c1	c2	c3
PNK SP 0160	923	420.5	264	390	34	305	213.5	31	513.5	229.5	107	423

# 单级旋片式真空泵

SINGLE STAGE -  
ROTARY VACUUM PUMP

安装尺寸图

## PNK SP 0200

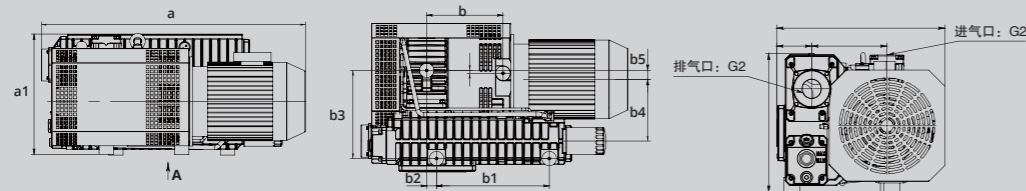

TYPE	a	a1	b	b1	b2	b3	b4	b5	c	c1	c2	c3
PNK SP 0200	923	420.5	264	390	34	305	213.5	31	513.5	229.5	107	423

## PNK SP 0250

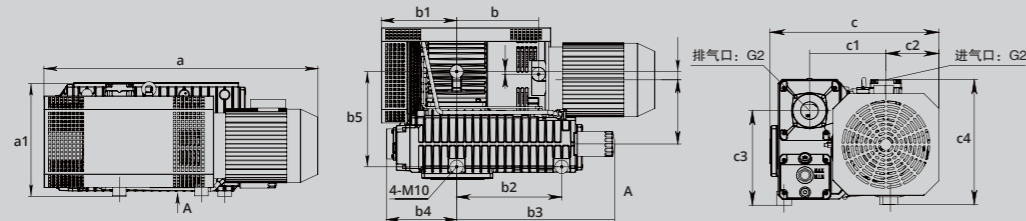

TYPE	a	a1	b	b1	b2	b3	b4	b5	c	c1	c2	c3	c4
PNK SP 0250	1014	422.5	304	280	390	586.5	261	354	562.5	254	177	315	415.5

## PNK SP 0300

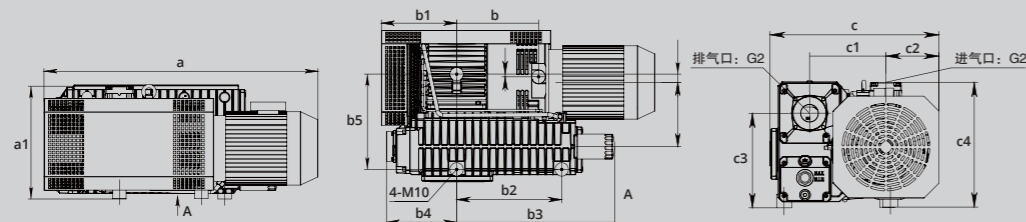

TYPE	a	a1	b	b1	b2	b3	b4	b5	c	c1	c2	c3	c4
PNK SP 0300	1014	422.5	304	280	390	586.5	261	354	562.5	254	177	315	415.5

# 双级旋片式真空泵

可靠耐用，适合粗真空和中真空应用

TWO STAGE OIL SEALED ROTARY VANE PUMPS  
PNK DP-C SERIES



# 双级旋片式真空泵

TWO STAGE -  
ROTARY VACUUM PUMP

## 性能特点

### 特性和优点

PNK DP-C系列泵是结实耐用的旋片式油封泵，抽速为0.7到275 m<sup>3</sup>/hr (30 到 206 CFM)。这些泵结构紧凑，使用时非常安静，具备先进的润滑回路，可靠性高，配有各种附件，可以满足特定的应用需求。

PNK DP-C系列双级油封旋转叶片真空泵因其高极限真空、高抽取速度、运行噪音小以及能够处理水蒸汽而享有盛誉。这些直接传动旋转式叶片泵设计紧凑且无振动，配备防伤手风扇和联轴器壳体，可为操作人员提供极佳的保护。

#### ■ 可靠性

可靠且稳定的制程 - 即使是在高气体负荷下也可提供有效的润滑

#### ■ 稳定

无制程污染 - 油和空气反吸保护

#### ■ 性能

长期无故障 - 传动轴杆上安装有工业级滚柱轴承

#### ■ 再保证

安心 - 经过多年尝试、测试，已经成为工业标准

可靠且稳定 - 高真空性能

### 应用领域

- 真空冶金加工
- 薄膜覆层技术
- 制药冷冻干燥
- 冷冻和空调系统抽空、干燥和回填

# 双级旋片式真空泵

TWO STAGE -  
ROTARY VACUUM PUMP

## 规格参数

		PNK DP 010C	PNK DP 016C	PNK DP 020C
额定流量 (50Hz) Rated airflow(50Hz)	m <sup>3</sup> / h	9.9	14	20
额定流量(60Hz) NRated airflow(60Hz)	m <sup>3</sup> / h	12	17.4	24
关气镇极限分压强 Ultimate partial pressure without gas ballast	mbar	7.0x10 <sup>-4</sup>	7.0x10 <sup>-4</sup>	7.0x10 <sup>-4</sup>
关气镇极限总压强1 Ultimate total pressure with small gas ballast	mbar	5.0x10 <sup>-3</sup>	5.0x10 <sup>-3</sup>	5.0x10 <sup>-3</sup>
开气镇极限总压强1 Ultimate total pressure with standard gas	mbar	5.0x10 <sup>-3</sup>	5.0x10 <sup>-3</sup>	2.0x10 <sup>-4</sup>
水蒸汽允许压强 Water vapor tolerance	mbar	20	20	20
口径 Diameter	DN(mm)	KF25	KF25	KF25
电机功率 Motor power	kw	0.4 (三/单)	0.55 (三/单)	0.75
电压(50Hz) Voltage(50Hz)	V	220-240/380-415	220-240/380-415	220-240/380-415
电压(60Hz) Voltage(60Hz)	V	220-280/380-440	220-280/380-440	220-280/380-440
电流(50Hz) Current(50Hz)	A	1.75/1.15	2.40/1.45	1.75/1.15
电流(60Hz) Current(60Hz)	A	2.10/1.38	2.88/1.74	2.10/1.38
转速(50Hz) Nominal speed(50Hz)	min	1400/1410	1400/1420	1400/1410
转速(60Hz) Nominal speed(60Hz)	min	1680/1710	1680/1710	1680/1710
噪音 Sound	db(A)	64	64	64
油量 Oil	L	1.1	1.2	1.5
重量 Weight	kg	24	27	32

1) 可根据需求定制特殊电压或马达

# 双级旋片式真空泵

## TWO STAGE - ROTARY VACUUM PUMP

### 规格参数

		PNK DP 030C	PNK DP 040C	PNK DP 060C
额定流量 (50Hz) Rated airflow(50HZ)	m <sup>3</sup> / h	30	40	60
额定流量(60Hz) NRated airflow(60Hz)	m <sup>3</sup> / h	36	48	72
关气镇极限分压强 Ultimate partial pressure without gas ballast	mbar	7.0x10 <sup>-4</sup>	7.0x10 <sup>-4</sup>	7.0x10 <sup>-4</sup>
关气镇极限总压强1 Ultimate total pressure with small gas ballast	mbar	5.0x10 <sup>-3</sup>	5.0x10 <sup>-3</sup>	5.0x10 <sup>-3</sup>
开气镇极限总压强1 Ultimate total pressure with standard gas	mbar	2.0x10 <sup>-4</sup>	2.0x10 <sup>-4</sup>	2.0x10 <sup>-4</sup>
水蒸汽允许压强 Water vapor tolerance	mbar	20	20	30
口径 Diameter	DN(mm)	KF40	KF40	KF40
电机功率 Motor power	kw	1.5	1.5	2.2
电压(50Hz) Voltage(50Hz)	V	220-240/380-415	220-240/380-415	220-240/380-420
电压(60Hz) Voltage(60Hz)	V	220-280/400-440	220-280/400-440	220-280/380-460
电流(50Hz) Current(50Hz)	A	6.5/3.5	6.5/3.5	9.57/5.40
电流(60Hz) Current(60Hz)	A	7.83/4.20	7.83/4.20	11.5/6.48
转速(50Hz) Nominal speed(50Hz)	min	1440/1420	1440/1420	1440
转速(60Hz) Nominal speed(60Hz)	min	1700/1720	1700/1720	1700/1720
噪音 Sound	db(A)	68	68	70
油量 Oil	L	1.2/2.8	1.2/2.8	2.5/4.2
重量 Weight	kg	63	63	91

1) 可根据需求定制特殊电压或马达

		PNK DP 080C	PNK DP 090C	PNK DP 175C
额定流量 (50Hz) Rated airflow(50HZ)	m <sup>3</sup> / h	80	90	175
额定流量(60Hz) NRated airflow(60Hz)	m <sup>3</sup> / h	96	108	180
关气镇极限分压强 Ultimate partial pressure without gas ballast	mbar	7.0x10 <sup>-4</sup>	7.0x10 <sup>-4</sup>	1.0x10 <sup>-3</sup>
关气镇极限总压强1 Ultimate total pressure with small gas ballast	mbar	5.0x10 <sup>-3</sup>	5.0x10 <sup>-3</sup>	5.0x10 <sup>-3</sup>
开气镇极限总压强1 Ultimate total pressure with standard gas	mbar	1.0x10 <sup>-2</sup>	1.0x10 <sup>-2</sup>	1.0x10 <sup>-2</sup>
水蒸汽允许压强 Water vapor tolerance	mbar	20	30	20
口径 Diameter	DN(mm)	KF40	KF40	KF50
电机功率 Motor power	kw	3.7	3.7	5.5
电压(50Hz) Voltage(50Hz)	V	220-240/380-415	220-240/380-420	220-240/380-415
电压(60Hz) Voltage(60Hz)	V	220-280/380-440	220-280/380-460	220-280/380-440
电流(50Hz) Current(50Hz)	A	1.75/1.15	13.4/7.70	22.9/13.3
电流(60Hz) Current(60Hz)	A	2.1/1.38	16.1/9.24	24.2/14.2
转速(50Hz) Nominal speed(50Hz)	min	1400/1410	1440	1440/1410
转速(60Hz) Nominal speed(60Hz)	min	1680/1710	1700/1720	1680/1710
噪音 Sound	db(A)	70	70	75
油量 Oil	L	4.0/6.3	2.5/4.2	16/25
重量 Weight	kg	105	104	200

1) 可根据需求定制特殊电压或马达

# 双级旋片式真空泵

TWO STAGE -  
ROTARY VACUUM PUMP

## 规格参数

		PNK DP 275C
额定流量 (50Hz) Rated airflow(50HZ)	m <sup>3</sup> / h	275
额定流量(60Hz) NRated airflow(60Hz)	m <sup>3</sup> / h	306
关气镇极限分压强 Ultimate partial pressure without gas ballast	mbar	1.0x10 <sup>-3</sup>
关气镇极限总压强1 Ultimate total pressure with small gas ballast	mbar	5.0x10 <sup>-3</sup>
开气镇极限总压强1 Ultimate total pressure with standard gas	mbar	1.0x10 <sup>-2</sup>
水蒸汽允许压强 Water vapor tolerance	mbar	20
口径 Diameter	DN(mm)	KF50
电机功率 Motor power	kw	7.5
电压(50Hz) Voltage(50Hz)	V	220-240/380-415
电压(60Hz) Voltage(60Hz)	V	220-280/380-440
电流(50Hz) Current(50Hz)	A	28.9/16.7
电流(60Hz) Current(60Hz)	A	29.7/17.3
转速(50Hz) Nominal speed(50Hz)	min	1400/1410
转速(60Hz) Nominal speed(60Hz)	min	1680/1710
噪音 Sound	db(A)	75
油量 Oil	L	16/25
重量 Weight	kg	200

1) 可根据需求定制特殊电压或马达

# 双级旋片式真空泵

TWO STAGE -  
ROTARY VACUUM PUMP

## 性能曲线

PNK DP 010C

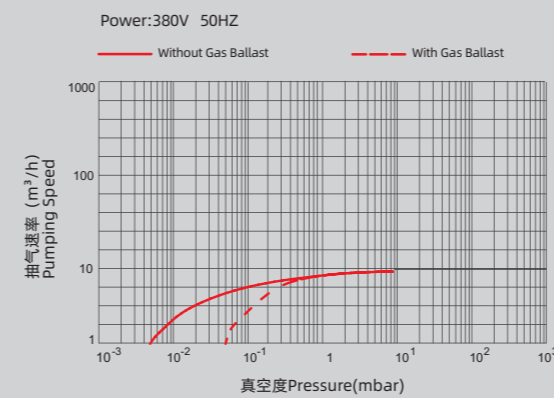

PNK DP 016C

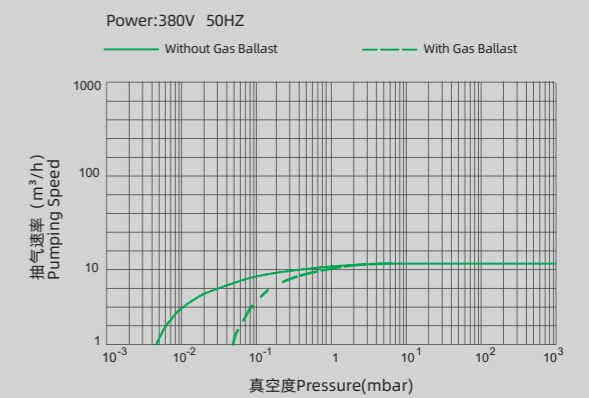

PNK DP 020C

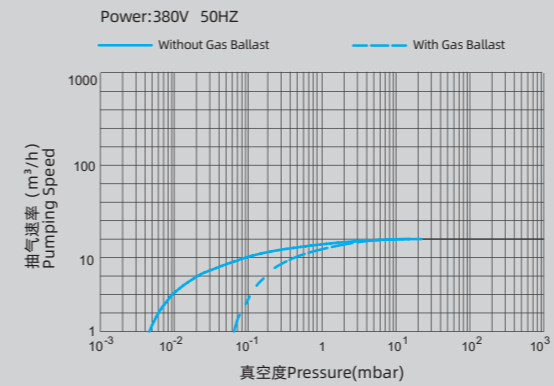

PNK DP 030C

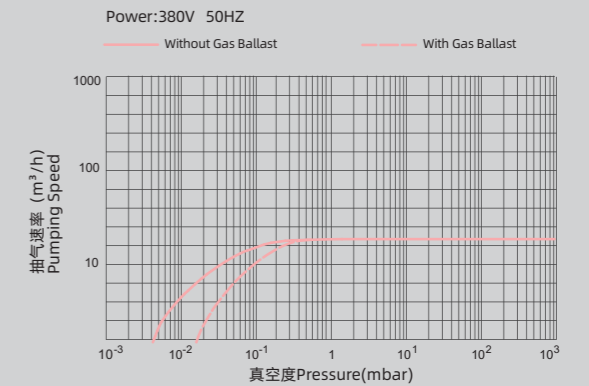

PNK DP 040C

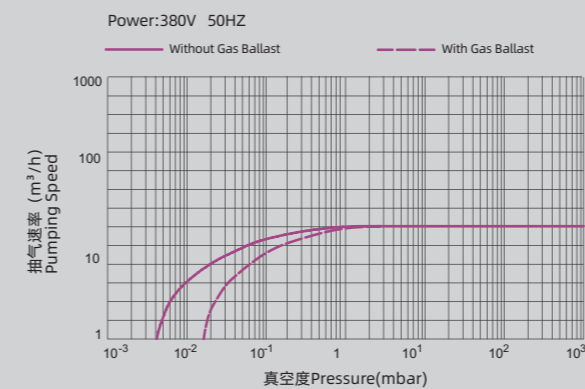

PNK DP 060C

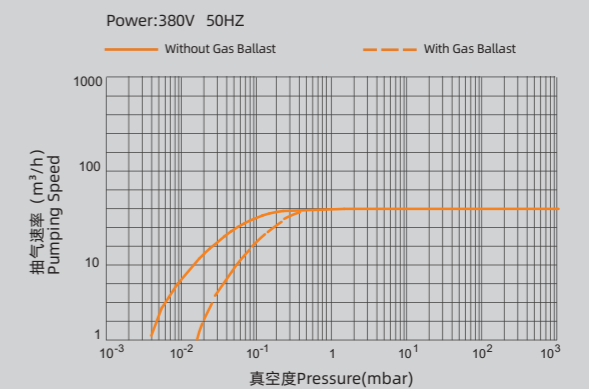

# 双级旋片式真空泵

TWO STAGE -  
ROTARY VACUUM PUMP

性能曲线

PNK DP 080C

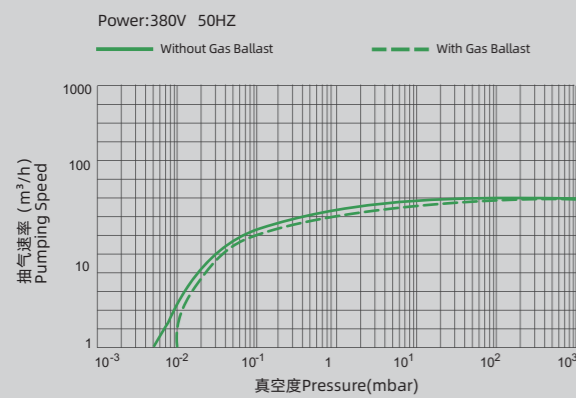

PNK DP 090C

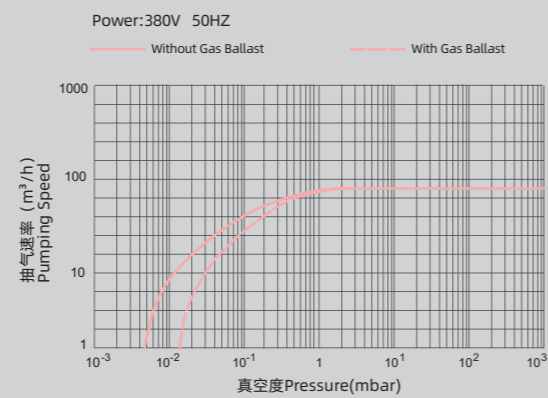

PNK DP 175C

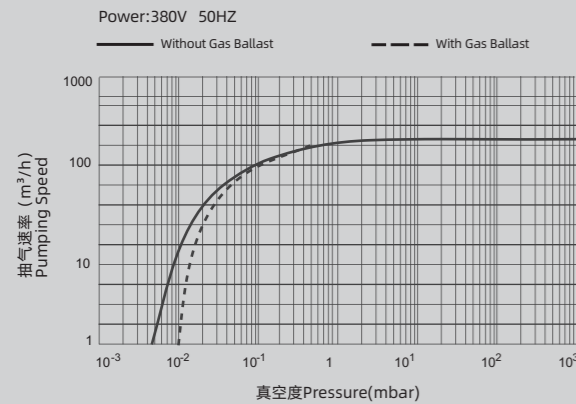

PNK DP 275C

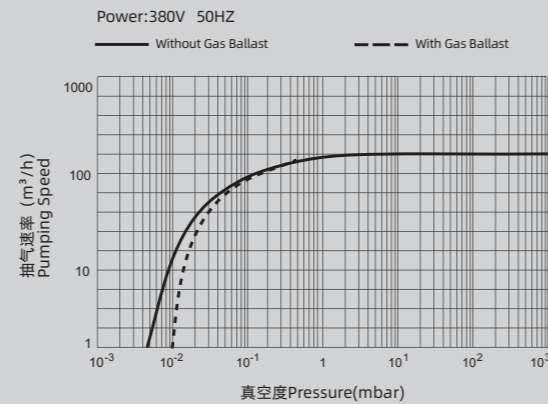

# 双级旋片式真空泵

TWO STAGE -  
ROTARY VACUUM PUMP

安装尺寸

PNK DP 010C

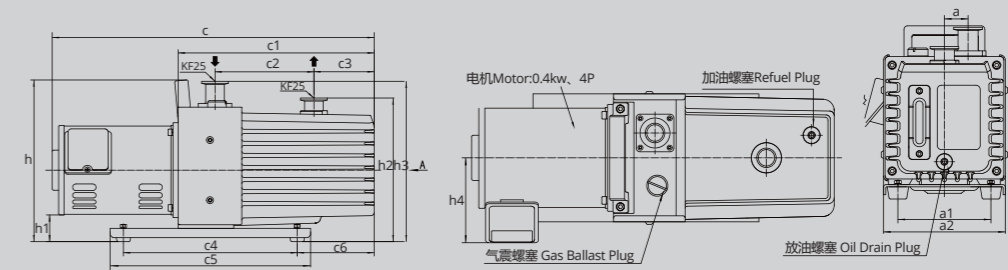

TYPE	a	a1	a2	a3	c	c1	c2	c3	c4	c5	c6	h	h1	h2	h3
PNK DP 010C	33	13	170	137	454	265	126	82	260	300	87	242	40	215	240

PNK DP 016C

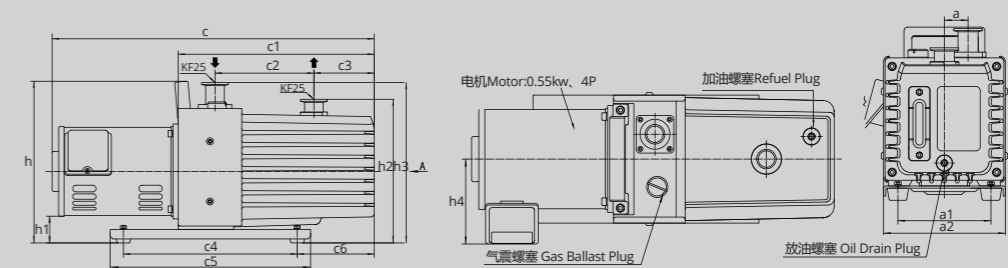

TYPE	a	a1	a2	a3	c	c1	c2	c3	c4	c5	c6	h	h1	h2	h3
PNK DP 016C	33	13	170	137	482	293	148	90	260	300	115	242	40	215	240

PNK DP 020C

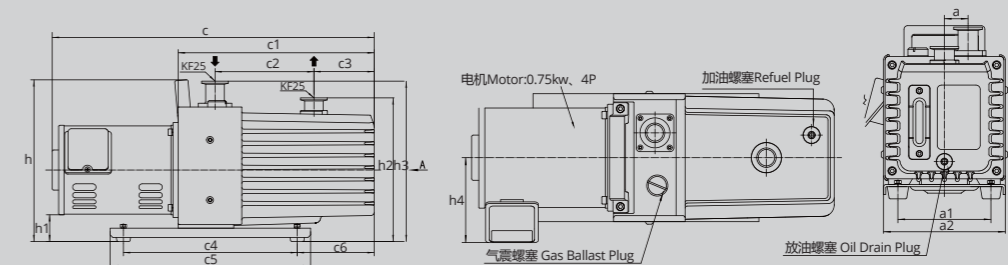

TYPE	a	a1	a2	a3	c	c1	c2	c3	c4	c5	c6	h	h1	h2	h3
PNK DP 020C	83	130	180	137	496	25	175	83	260	300	136	263	40	215	252

# 双级旋片式真空泵

## TWO STAGE - ROTARY VACUUM PUMP

### 安装尺寸

PNK DP 030C

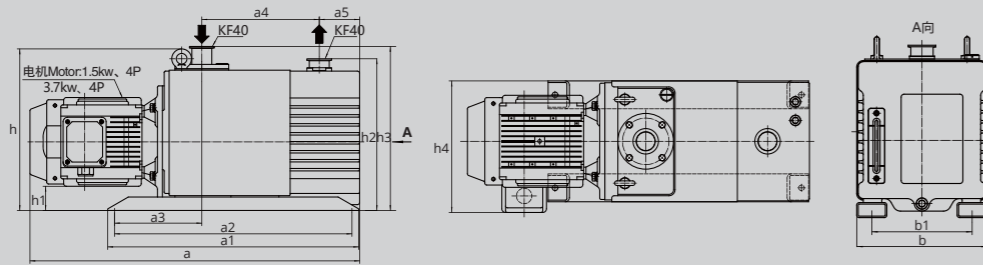

TYPE	a	a1	a2	a3	a4	a5	b	b1	h	h1	h2	h3	h4
PNK DP 030C	606	500	470	185	215	87	210	150	340	68	348	346	260

PNK DP 040C

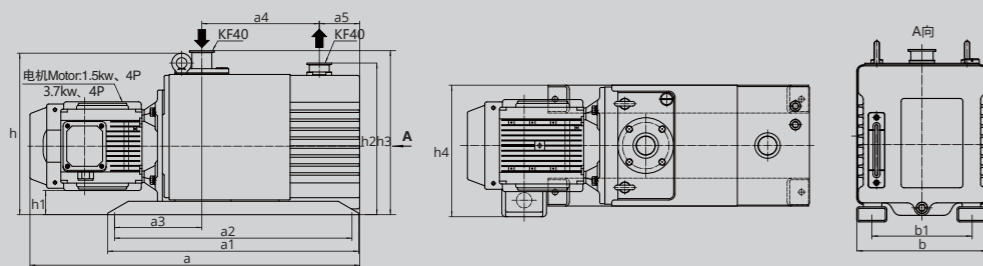

TYPE	a	a1	a2	a3	a4	a5	b	b1	h	h1	h2	h3	h4
PNK DP 040C	606	500	470	185	215	87	210	150	340	68	348	346	260

PNK DP 060C

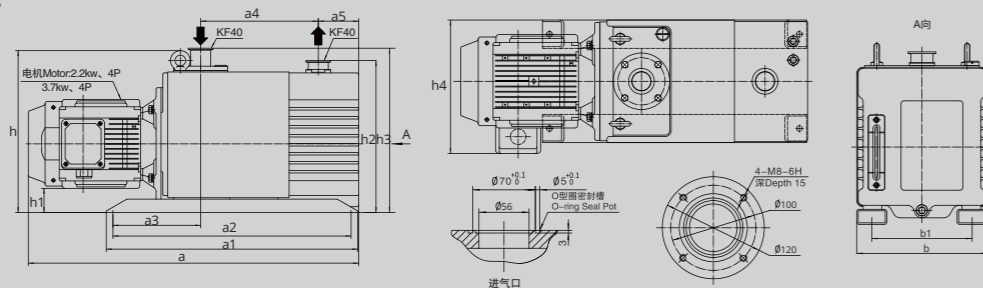

TYPE	a	a1	a2	a3	a4	a5	b	b1	h	h1	h2	h3	h4
PNK DP 060C	736	560	530	195	262	90	260	200	360	54	339	366	283

PNK DP 080C

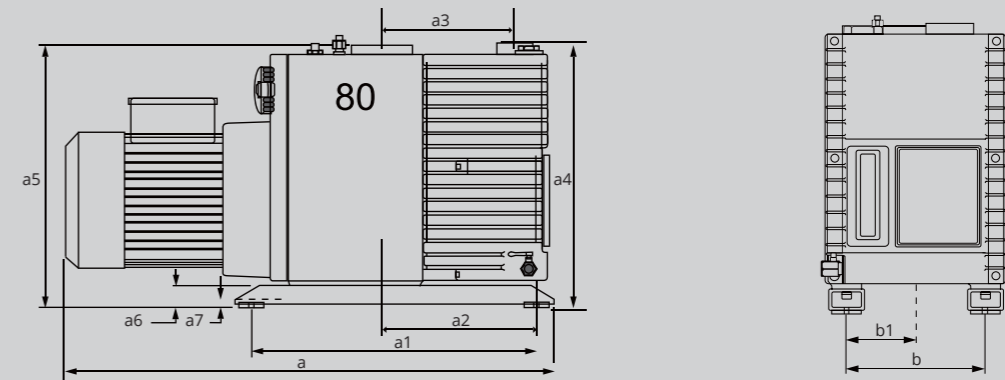

TYPE	a	a1	a2	a3	a4	a5	a6	a7	b	b1
PNK DP 080C	815	550	255	220	430	428	36	9	196	98

PNK DP 090C

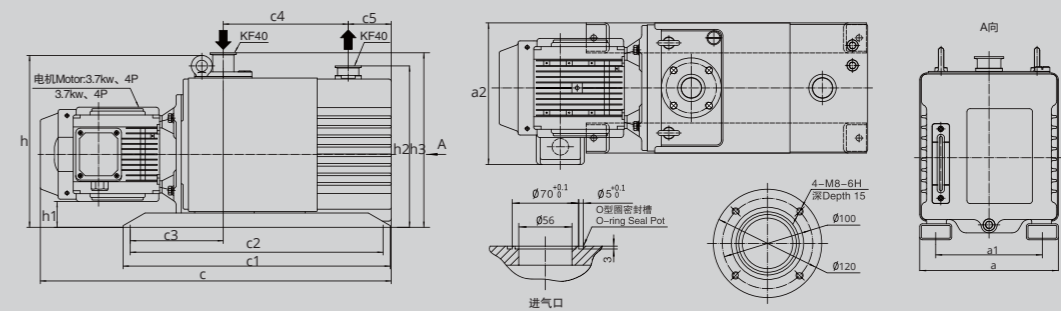

TYPE	a	a1	a2	c	c1	c2	c3	c4	c5	h	h1	h2	h3
PNK DP 090C	260	200	283	736	560	530	195	262	90	360	54	339	366

# 双级旋片式真空泵

TWO STAGE -  
ROTARY VACUUM PUMP

安装尺寸

# 双级旋片式真空泵

可靠耐用，适合粗真空和中真空应用

TWO STAGE OIL SEALED ROTARY VANE PUMPS  
PNK DP-D SERIES

PNK DP 175C

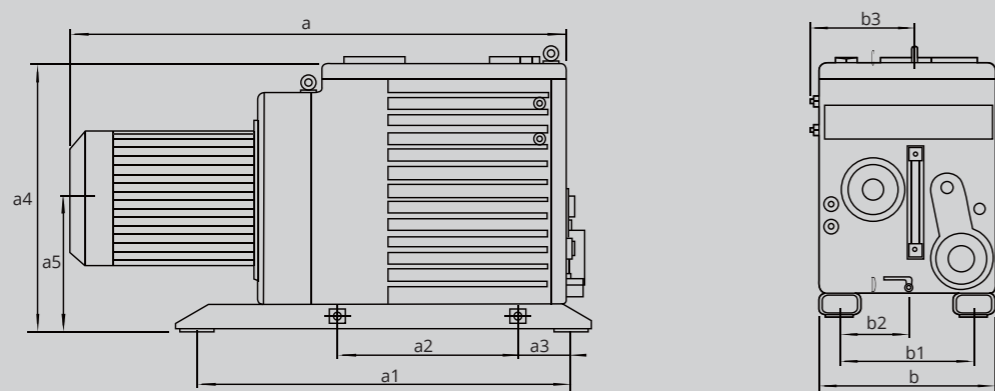

TYPE	a	a1	a2	a3	a4	a5	b	b1	b2	b3
PNK DP 175C	1085	800	390	112	518	248	404	388	145	155

PNK DP 275C

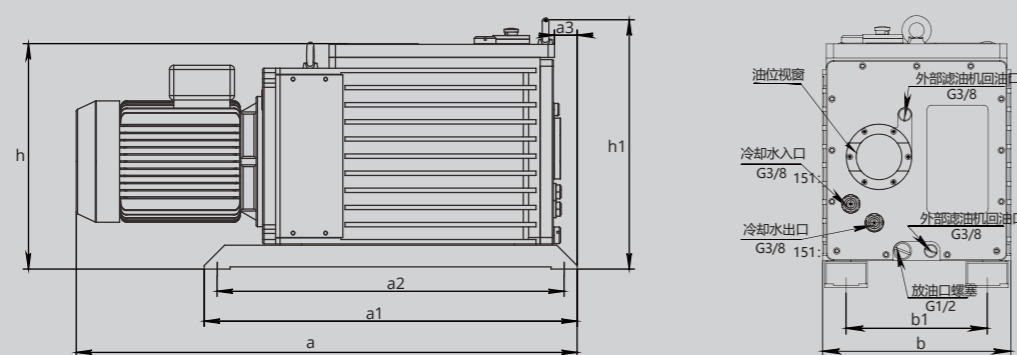

TYPE	a	a1	a2	a3	b	b1	h	h1
PNK DP 275C	1155	865	800	52	400	300	520	575





# 双级旋片式真空泵

可靠耐用，适合粗真空和中真空应用

## TWO STAGE - OIL SEALED ROTARY VANE PUMPS

### 特性和优点

Pronotek D系列双级油封旋转叶片真空泵因其高极限真空、高抽取速度、运行噪音小以及能够处理水蒸汽而享有盛誉。这些直接传动旋转式叶片泵设计紧凑且无振动，配备防伤手风扇和联轴器壳体，可为操作人员提供极佳的保护。

#### ■ 可靠性

可靠且稳定的制程 - 即使是在高气体负荷下也可提供有效的润滑

#### ■ 稳定

无制程污染 - 油和空气反吸保护

#### ■ 性能

长期无故障 - 传动轴杆上安装有工业级滚柱轴承

#### ■ 再保证

安心 - 经过多年尝试、测试，已经成为工业标准

可靠且稳定 - 高真空性能

### 应用领域

- 真空冶金加工
- 薄膜覆层技术
- 制药冷冻干燥
- 冷冻和空调系统抽空、干燥和回填

# 双级旋片式真空泵

## TWO STAGE - ROTARY VACUUM PUMP

### 规格参数

		PNK DP 008D	PNK DP 018D	PNK DP 036D
抽速(50Hz) Nominal pumping speed(50Hz)	m <sup>3</sup> / h	8	18	36
抽速(60Hz) Nominal pumping speed(60Hz)	m <sup>3</sup> / h	9.6	21.6	43.0
关气镇极限分压强 Ultimate partial pressure without gas ballast	mbar	4x10 <sup>-4</sup>	4x10 <sup>-4</sup>	4x10 <sup>-4</sup>
关气镇极限总压强1 Ultimate total pressure with small gas ballast	mbar	3x10 <sup>-3</sup>	3x10 <sup>-3</sup>	3x10 <sup>-3</sup>
开气镇极限总压强1 Ultimate total pressure with standard gas	mbar	6x10 <sup>-3</sup>	6x10 <sup>-3</sup>	6x10 <sup>-3</sup>
水蒸汽允许压强 Water vapor tolerance	mbar	30	30	40
连接口(进气口/排气口) Intake connection / Exhasust connection	DN(mm)	KF25	KF25	KF40
噪音(当气镇关/开时,距离1米处声压电平值) Noise	dB(A)	54/56	55/58	58/60
注油量(最大/最小) Oil volume (Max / Min)	L	1.0/0.7	1.5/1.0	3.8/3.3
重量(未注油) Weight(without Oil)	kg	27	31	69
工作环境温度(最低/最高) Ambient Temp.(Min/Max)	°C	5/40	5/40	5/40
电机功率(单相 220V 50Hz) Motor Power(single phase,220V/50Hz)	W	550	750	-
电机功率(三相 380V 50Hz) Motor power(Three phase,380V/50Hz)	W	550	550	1500
泵总高度 Pump Total Length	mm	272	272	370
泵总长度 Pump Total heigth	mm	500	540	661

1) 可根据需求定制特殊电压或马达

# 双级旋片式真空泵

TWO STAGE -  
ROTARY VACUUM PUMP

## 规格参数

		PNK DP 048D	PNK DP 065D
抽速(50Hz) Nominal pumping speed(50Hz)	m <sup>3</sup> / h	48	65
抽速(60Hz) Nominal pumping speed(60Hz)	m <sup>3</sup> / h	57	78
关气镇极限分压强 Ultimate partial pressure without gas ballast	mbar	4x10 <sup>-4</sup>	4x10 <sup>-4</sup>
关气镇极限总压强1 Ultimate total pressure with small gas ballast	mbar	3x10 <sup>-3</sup>	3x10 <sup>-3</sup>
开气镇极限总压强1 Ultimate total pressure with standard gas	mbar	6x10 <sup>-3</sup>	6x10 <sup>-3</sup>
水蒸汽允许压强 Water vapor tolerance	mbar	30	30
连接口(进气口/排气口) Intake connection / Exhasust connection	DN(mm)	KF40	KF40
噪音(当气镇关/开时,距离1米处声压电平值) Noise	dB(A)	58/60	58/60
注油量(最大/最小) Oil volume (Max / Min)	L	5.0/4.6	5.0/4.6
重量(未注油) Weight(without Oil)	kg	82	80
工作环境温度(最低/最高) Ambient Temp.(Min/Max)	°C	5/40	5/40
电机功率(单相 220V 50Hz) Motor Power(single phase,220V/50Hz)	W	-	-
电机功率(三相 380V 50Hz) Motor power(Three phase,380V/50Hz)	W	1500	2200
泵总高度 Pump Total Length	mm	370	370
泵总长度 Pump Total heigth	mm	765	765

1) 可根据需求定制特殊电压或马达

# 双级旋片式真空泵

TWO STAGE -  
ROTARY VACUUM PUMP

## 性能曲线

PNK DP 008D

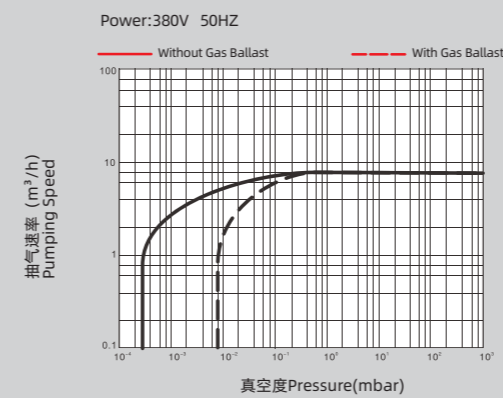

PNK DP 018D

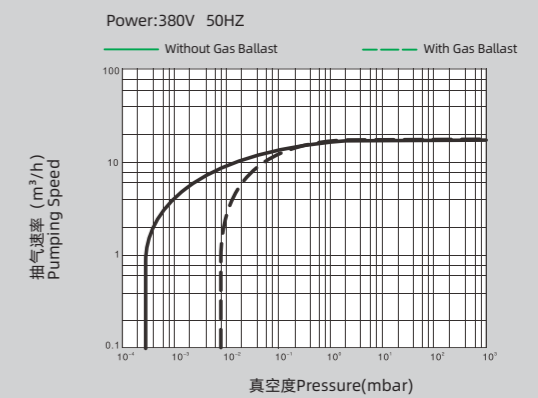

PNK DP 036D

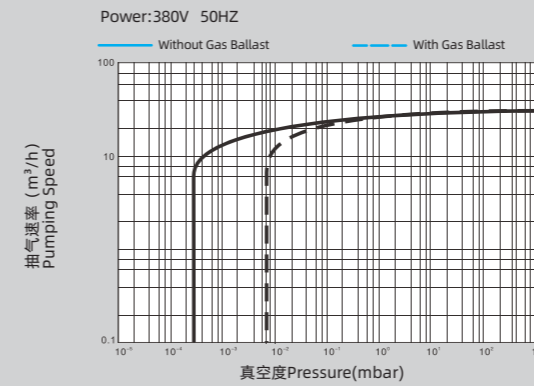

PNK DP 048D

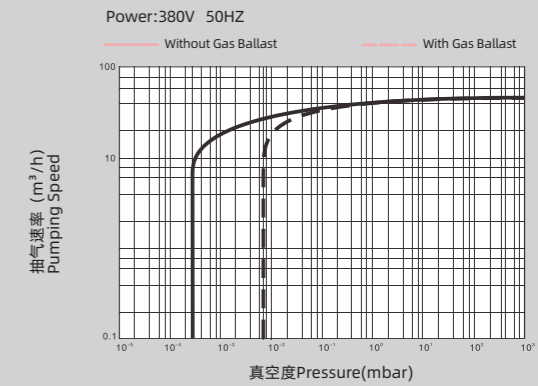

PNK DP 065D

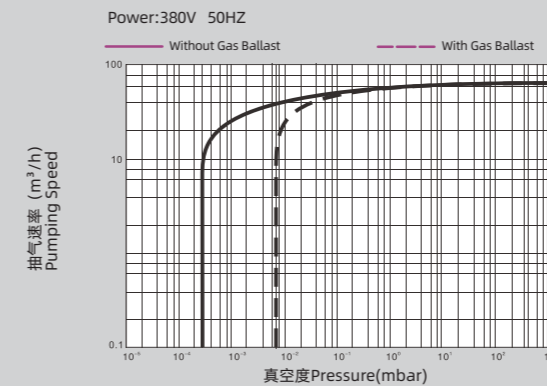

# 双级旋片式真空泵

## TWO STAGE - ROTARY VACUUM PUMP

### 安装尺寸

PNK DP 008D

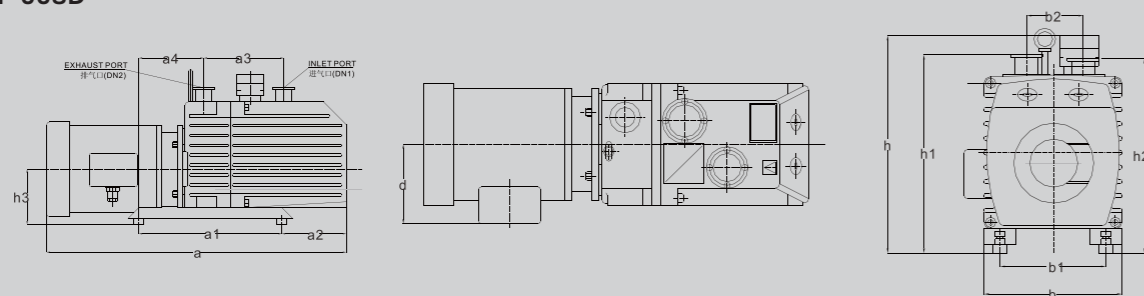

TYPE	Dn1	Dn2	a	a1	a2	a3	a4	b	b1	b2	h	h1	h2	h3	d
PNK DP 008D	KF25	KF25	500	260	75	146	118	173	133	71	272	243	246	100	160

PNK DP 048D

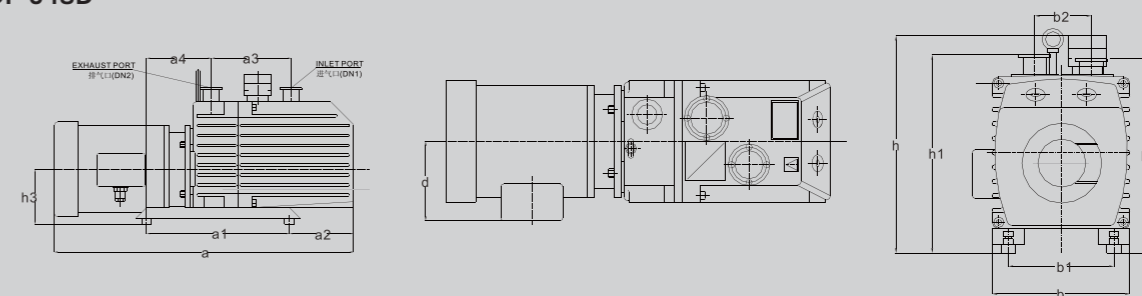

TYPE	Dn1	Dn2	a	a1	a2	a3	a4	b	b1	b2	h	h1	h2	h3	d
PNK DP 048D	KF40	KF40	765	395	198	224	185	242	192	90	370	358	362	166	153

PNK DP 018D

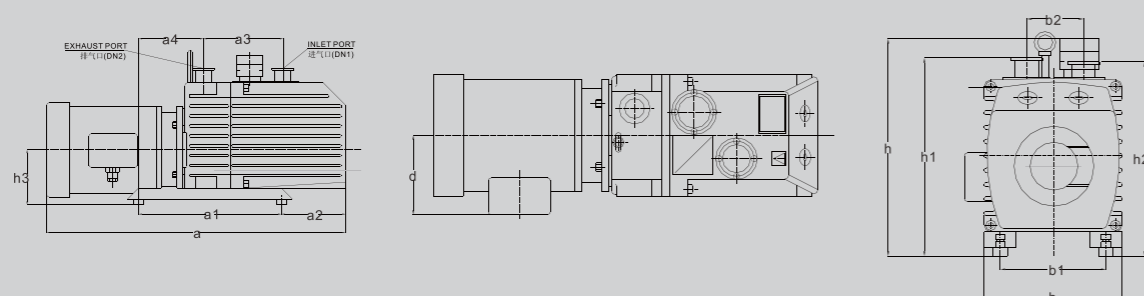

TYPE	Dn1	Dn2	a	a1	a2	a3	a4	b	b1	b2	h	h1	h2	h3	d
PNK DP 018D	KF25	KF25	540	260	117	146	118	173	133	71	272	243	246	100	160

PNK DP 065D

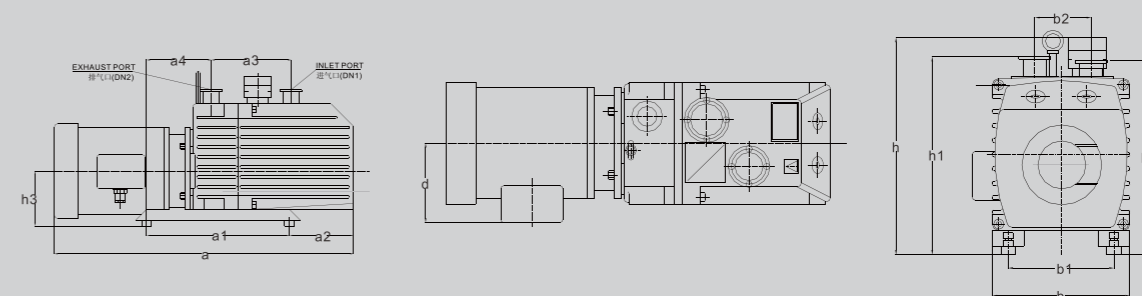

TYPE	Dn1	Dn2	a	a1	a2	a3	a4	b	b1	b2	h	h1	h2	h3	d
PNK DP 065D	KF40	KF40	765	395	198	224	185	242	192	90	370	358	362	166	153

PNK DP 036D

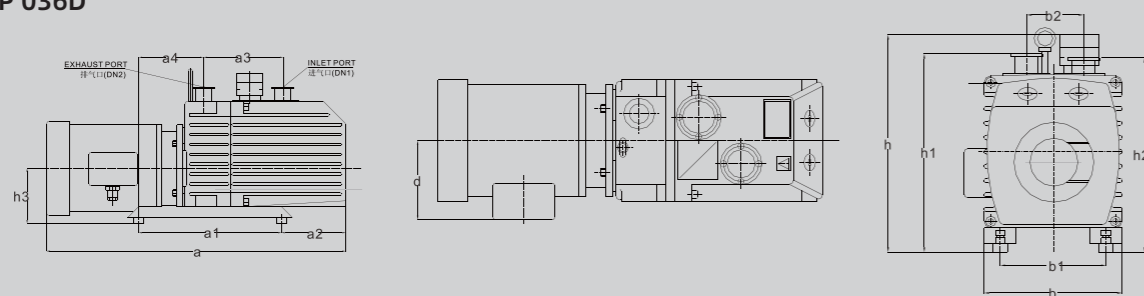

TYPE	Dn1	Dn2	a	a1	a2	a3	a4	b	b1	b2	h	h1	h2	h3	d
PNK DP 036D	KF40	KF40	661	395	123	224	185	242	192	90	370	358	362	166	153

# 罗茨真空泵

既可以增大抽速又能提高极限

ROOTS MECHANICAL BOOSTER PUMPS

PNK MR-C SERIES



## 特性和优点

Pronotek MR-C系列罗茨泵是无油运行的真空泵，需配合前级泵使用，适用于所有需要大吸气量的粗真空和高真空应用。此类加强型真空泵大大提高了前级泵的输出。普诺克MR系列罗茨真空泵产品抽速范围在100到1100m<sup>3</sup>/h之间。它们可以安全地应用于各类中、低真空用途中，包括镀膜、半导体行业、研发、冶金或化学以及工艺技术中。

### ■ 系列全

完整的罗茨泵产品系列，具有高度的灵活性，能最大程度满足工艺需求

### ■ 抽速范围大

从100到1,100m<sup>3</sup>/h的抽速范围

### ■ 性能卓越

坚固耐用，设计紧凑，高压比配合溢流阀实现快速排气，磁耦合驱动，免维护，运行可靠，无故障运行时间长

### ■ 再保证

风冷结合磁耦合驱动大大降低运行成本  
得益于溢流阀的整体设计，有效防止泵体温度过高  
保养间隔时间长，现场维护简单易操作  
提供全球范围内的现场检修服务

## 应用领域

■ 冶金

■ 空间模拟

■ 包装行业

■ 冷冻/真空干燥

■ 薄膜技术

电子束焊接 ■

预真空锁 ■

化工技术 ■

工业检漏系统 ■

钢业脱气 ■

# 罗茨真空泵

ROOTS TYPE  
MECHANICAL BOOSTER PUMPS

## 规格参数

	PNK MR 0100C	PNK MR 0300C	PNK MR 0500C	PNK MR 1100C
额定流量 Rated airflow	100m <sup>3</sup> /h	300m <sup>3</sup> /h	500m <sup>3</sup> /h	1100m <sup>3</sup> /h
极限压力 Ultimate pressure	1x10 <sup>-1</sup> mbar(abs)	≤1x10 <sup>-3</sup> mbar(abs)	≤1x10 <sup>-3</sup> mbar(abs)	≤1x10 <sup>-3</sup> mbar(abs)
口径 Diameter	VG50	VG80	VG63/ISO100	VG80/ISO100
电机功率 Mptor power	0.4kw	0.75kw	2.2kw	3.7kw
电压 Volage	320-440v	320-440v	320V-440V	320-440v
电流 Current	0.9A	1.8A	3.9/4.0A	4.9/5.0A
转速 Nominal speed	2855/3600Min <sup>-1</sup>	2885/3600Min <sup>-1</sup>	900/1120Min <sup>-1</sup>	1400/1720Min <sup>-1</sup>
噪音 Noise	68dB(A)	68dB(A)	68dB(A)	70dB(A)
油量 Oil volume	0.4L	0.8L	4.6/5.0L	4.6/5.0L
重量 Weight	30kg	51kg	79.5kg	215kg

# 罗茨真空泵

ROOTS TYPE  
MECHANICAL BOOSTER PUMPS

## 性能曲线

PNK MR 0100C

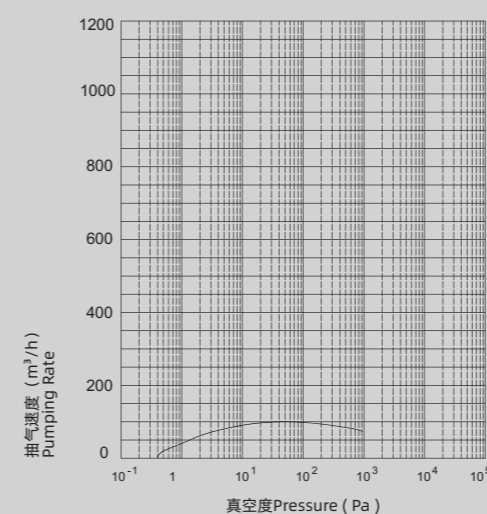

PNK MR 0300C

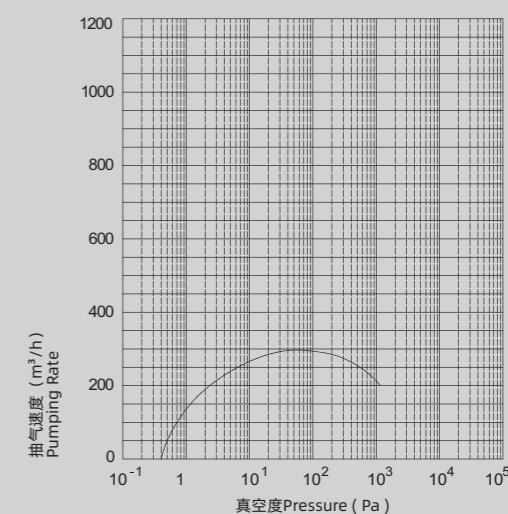

PNK MR 0500C

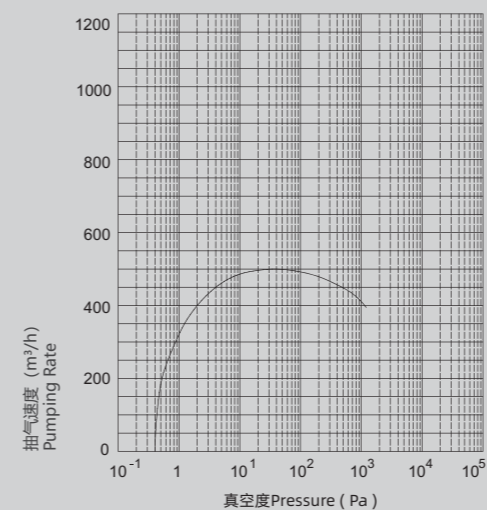

PNK MR 1100C

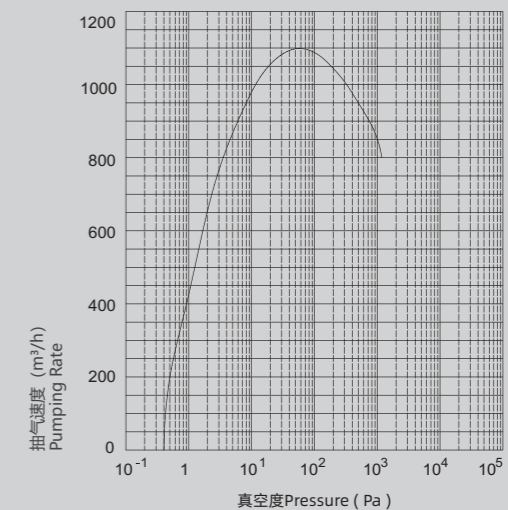

# 罗茨真空泵

## ROOTS TYPE MECHANICAL BOOSTER PUMPS

### 安装尺寸

PNK MR 0100C

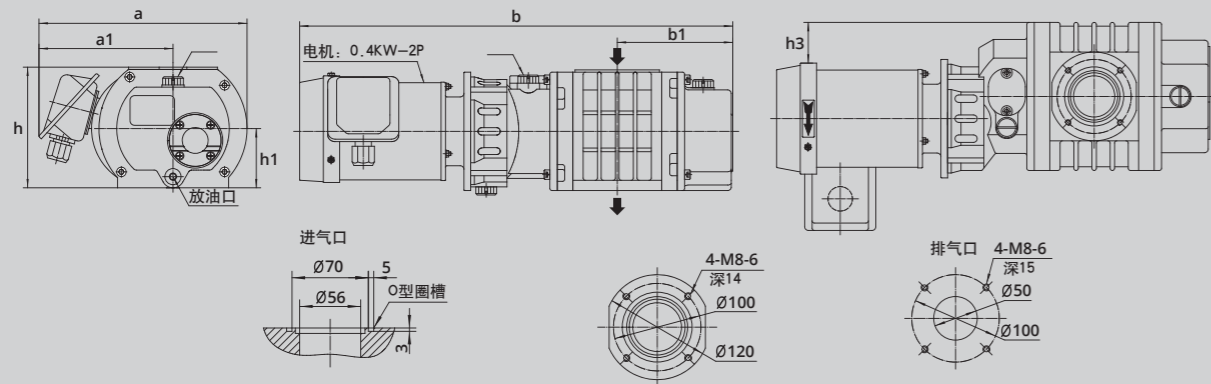

TYPE	a	a1	h	h1	h3	b	b1
PNK MR 0100C	281	181	163	80	55	586	156

PNK MR 0500C

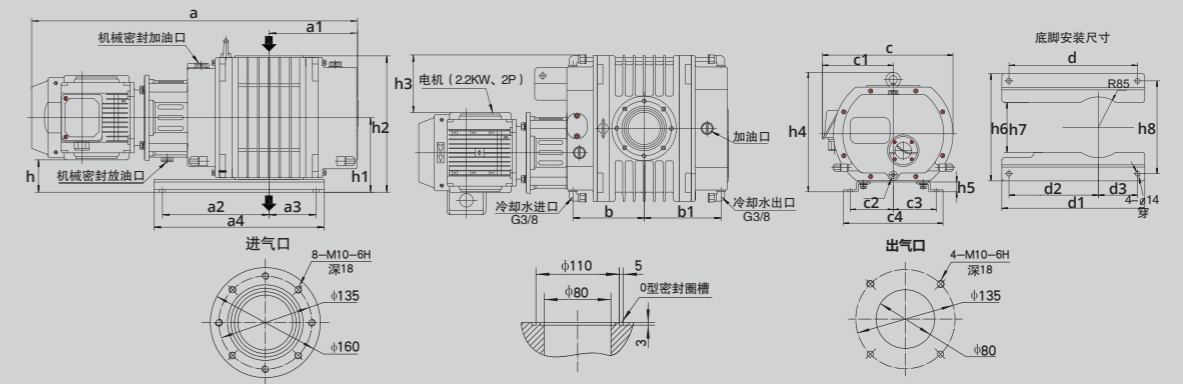

TYPE	a	a1	a2	a3	a4	b	b1	c	c1	c2	c3	c4	d	d1	d2	d3	h	h1	h2	h3	h4	h5	h6	h7	h8
PNK MR 0500C	764	208	250	110	400	176	190	393	213	130	130	300	360	400	250	110	76	175	320	143	366	30	300	140	260

PNK MR 0300C

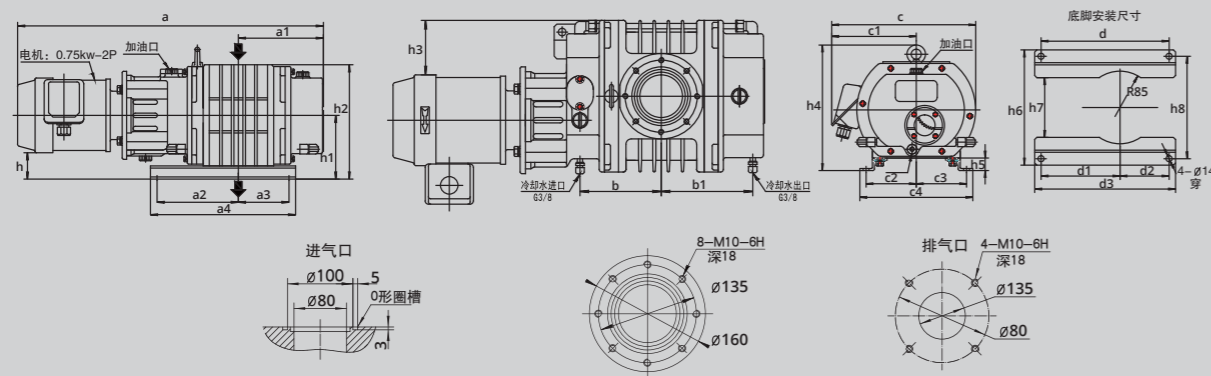

TYPE	a	a1	a2	a3	a4	b	b1	c	c1	c2	c3	c4	d	d1	d2	d3	h	h1	h2	h3	h4	h5	h6	h7	h8
PNK MR 0300C	695	193	185	115	330	152	172	345	203	120	120	270	300	185	115	330	60	145	260	102	300	30	270	140	240

PNK MR 1100C

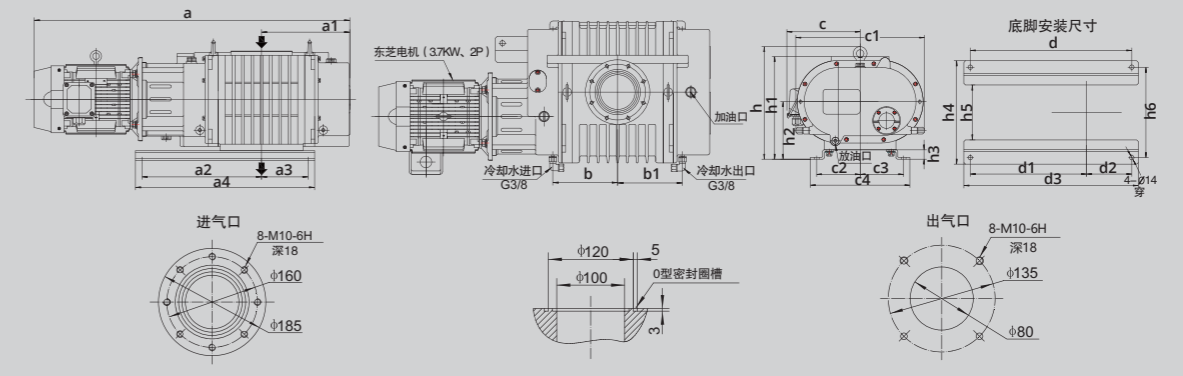

TYPE	a	a1	a2	a3	a4	b	b1	c	c1	c2	c3	c4	d	d1	d2	d3	h	h1	h2	h3	h4	h5	h6
PNK MR 1100C	951	266	360	140	540	186	186	236	415	140	140	320	500	360	140	540	362	330	185	30	320	170	280

# 罗茨真空泵

既可以增大抽速又能提高极限

ROOTS MECHANICAL BOOSTER PUMPS

PNK MR-Y SERIES

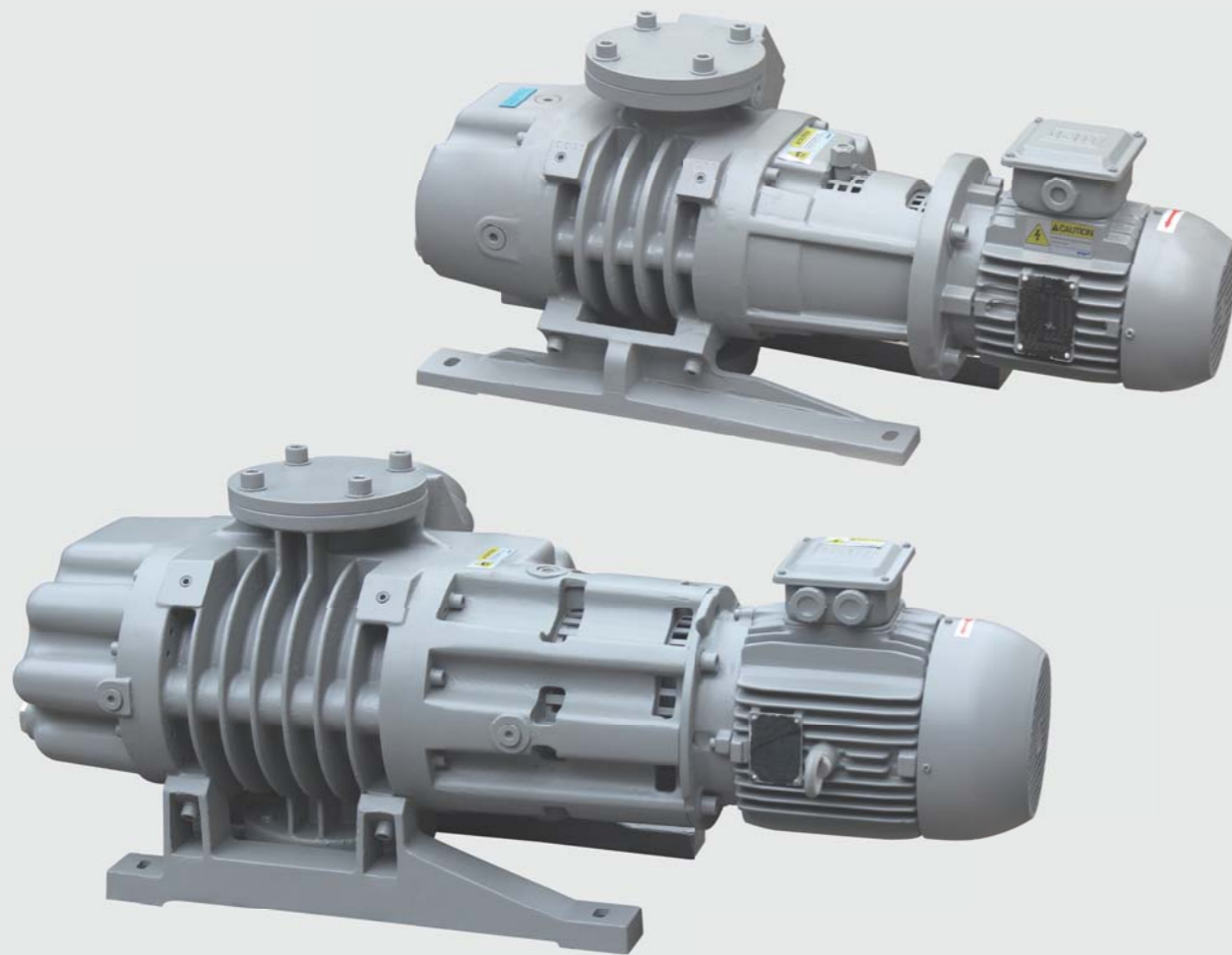

## 特性和优点

Pronotek MR-Y系列罗茨泵是无油运行的真空泵，需配合前级泵使用，适用于所有需要大吸气量的粗真空和高真空应用。此类加强型真空泵大大提高了前级泵的输出。普诺克MR系列罗茨真空泵产品抽速范围在250到2,000m<sup>3</sup>/h之间。它们可以安全地应用于各类中、低真空用途中，包括镀膜、半导体行业、研发、冶金或化学以及工艺技术中。

### ■ 系列全

完整的罗茨泵产品系列，具有高度的灵活性，能最大程度满足工艺需求

### ■ 抽速范围大

从250到2,000m<sup>3</sup>/h的抽速范围

### ■ 性能卓越

坚固耐用，设计紧凑，高压比配合溢流阀实现快速排气，磁耦合驱动，免维护，运行可靠，无故障运行时间长

### ■ 再保证

风冷结合磁耦合驱动大大降低运行成本  
得益于溢流阀的整体设计，有效防止泵体温度过高  
保养间隔时间长，现场维护简单易操作  
提供全球范围内的现场检修服务

## 应用领域

- 冶金
- 空间模拟
- 包装行业
- 冷冻/真空干燥
- 薄膜技术
- 电子束焊接
- 预真空锁
- 化工技术
- 工业检漏系统
- 钢业脱气

# 罗茨真空泵

ROOTS TYPE  
MECHANICAL BOOSTER PUMPS

## 规格参数

		PNK MR 250Y	PNK MR 500Y	PNK MR 1000Y	PNK MR 2000Y
额定流量 Pumping speed	m <sup>3</sup> /h	250	500	1000	2000
极限分压力 Ultimate pressure	Pa	0.05			
极限全分压力 Extreme full pressure	Pa	0.5			
最大允许压差 Max. differential pressure	Pa	8000			5000
进口气口通 In and out of caliber	mm	65	100		150
零流量最大压缩比 Max. of 0 flow compression rate	max	≥35	≥40		≥50
噪音 Noise	dB(A)	63	68		75
电机功率 Motor power	kw	1.1	2.2	4	7.5
电机同步转速 Motorsynchronous speed	r/min	3000			
冷却方式 Cooling model		自然风冷natural air cooling			
推荐前级泵 Recommend backing pump models		PNK SP 0100	PNK SP 0160	PNK SP 0300	PNK SP 0630
重量 Weight	kg	100	155	233	465

# 罗茨真空泵

ROOTS TYPE  
MECHANICAL BOOSTER PUMPS

## 性能曲线

PNK MR 250Y

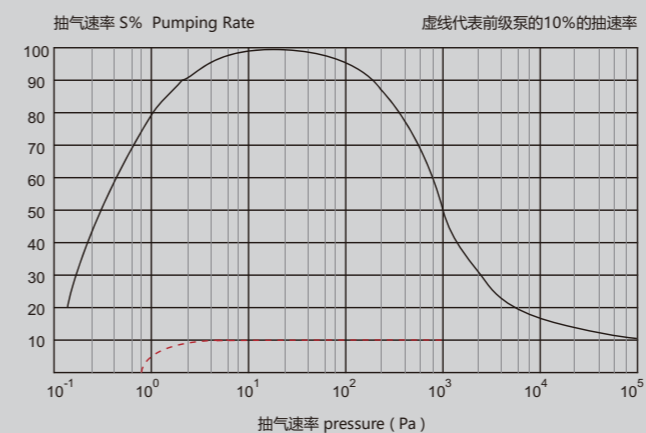

PNK MR 500Y

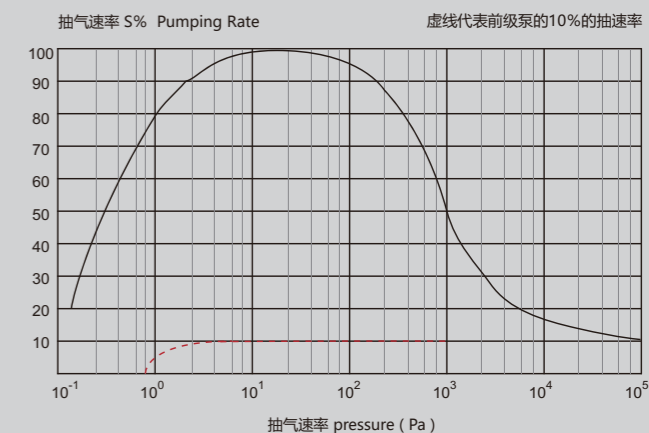

PNK MR 1000Y

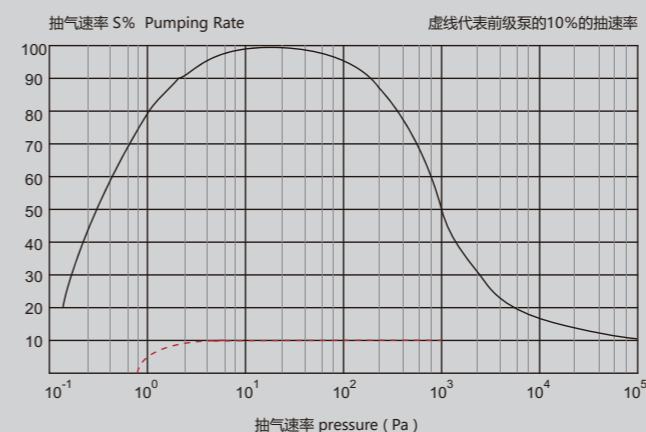

PNK MR 2000Y

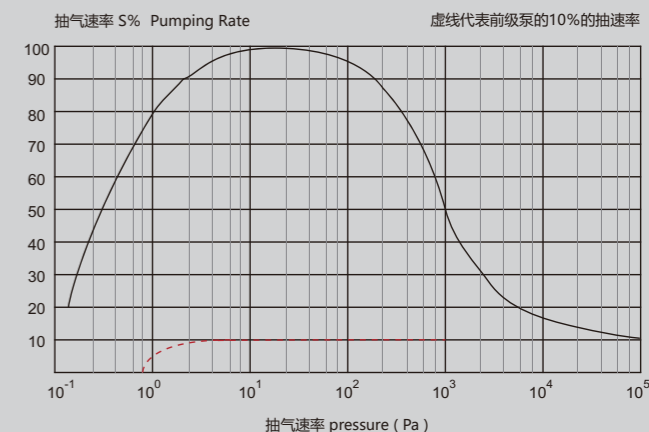



# 罗茨真空泵

## ROOTS TYPE MECHANICAL BOOSTER PUMPS

### 安装尺寸

PNK MR 250Y

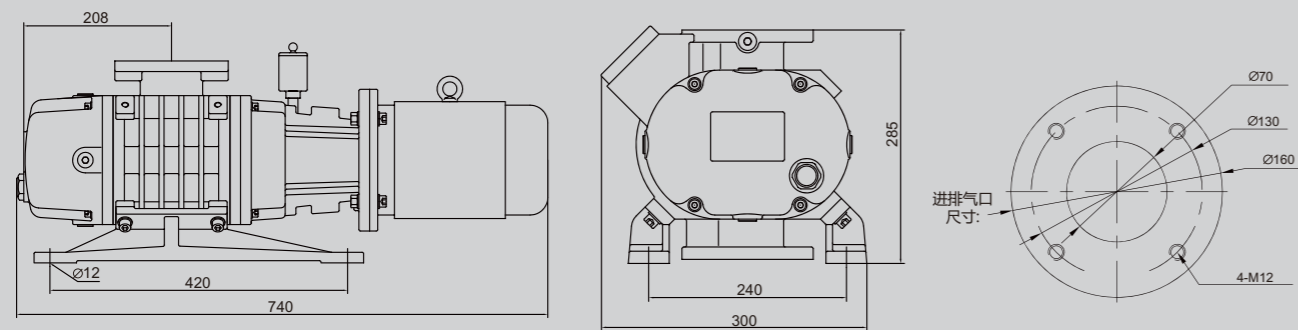

PNK MR 1000Y

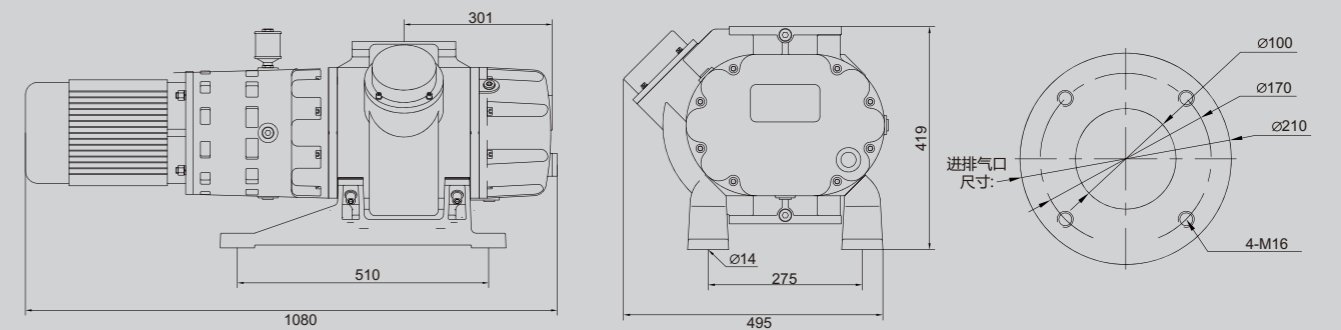

PNK MR 500Y

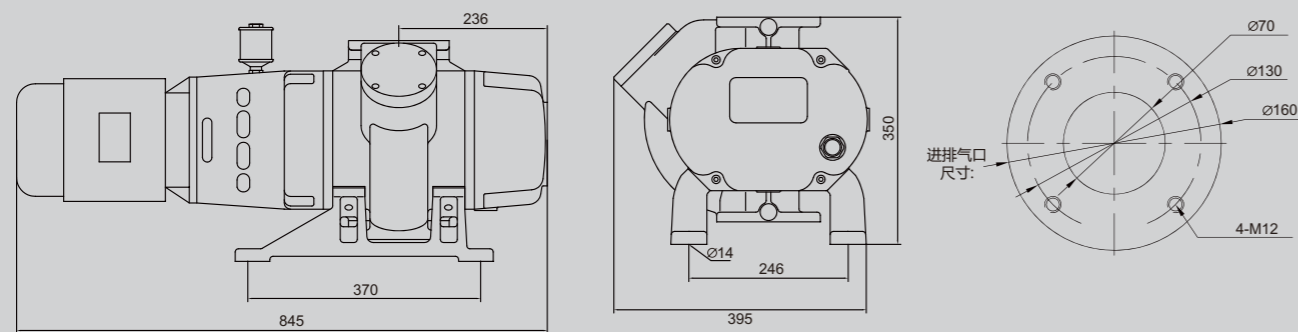

PNK MR 2000Y

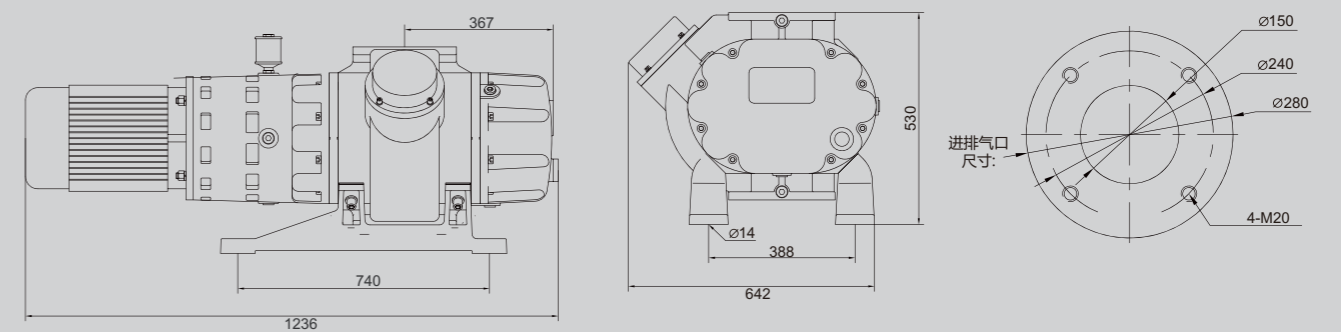

# 罗茨真空泵

既可以增大抽速又能提高极限

ROOTS MECHANICAL BOOSTER PUMPS

PNK MR-T SERIES



## 特性和优点

Pronotek MR-T系列罗茨泵是无油运行的真空泵，需配合前级泵使用，适用于所有需要大吸气量的粗真空和高真空应用。此类加强型真空泵大大提高了前级泵的输出。普诺克MR系列罗茨真空泵产品抽速范围在300到36,000m<sup>3</sup>/h之间。它们可以安全地应用于各类中、低真空用途中，包括镀膜、半导体行业、研发、冶金或化学以及工艺技术中。

### ■ 系列全

完整的罗茨泵产品系列，具有高度的灵活性，能最大程度满足工艺需求

### ■ 抽速范围大

从300到36,000m<sup>3</sup>/h的抽速范围

### ■ 性能卓越

坚固耐用，设计紧凑，高压比配合溢流阀实现快速排气，磁耦合驱动，免维护，运行可靠，无故障运行时间长

### ■ 再保证

风冷结合磁耦合驱动大大降低运行成本  
得益于溢流阀的整体设计，有效防止泵体温度过高  
保养间隔时间长，现场维护简单易操作  
提供全球范围内的现场检修服务

## 应用领域

■ 冶金

■ 空间模拟

■ 包装行业

■ 冷冻/真空干燥

■ 薄膜技术

电子束焊接 ■

预真空锁 ■

化工技术 ■

工业检漏系统 ■

钢业脱气 ■

# 罗茨真空泵

ROOTS TYPE

MECHANICAL BOOSTER PUMPS

## 规格参数

	PNK MR 0300T	PNK MR 0600T	PNK MR 1100T	PNK MR 2200T
额定流量 Rated airflow	300m <sup>3</sup> /h	600m <sup>3</sup> /h	1100m <sup>3</sup> /h	2200m <sup>3</sup> /h
	70L/S	150L/S	300L/S	600L/S
极限压力 Ultimate pressure	≤0.05pa	≤0.05pa	≤0.05pa	≤0.05pa
最大允许压差 Max.Differential pressure	≥1.2×10 <sup>4</sup> pa	≥1.2×10 <sup>4</sup> pa	≥1×10 <sup>4</sup> pa	≥8×10 <sup>3</sup> pa
电机功率 Motor power	1.5kw	3kw	4kw	5.5 (7.5) kw
转速 Nominal speed	2900rpm	2900rpm	2900rpm	2900rpm
进气口 Suction	100mm	100mm	150mm	200mm
排气口 Discharge	80mm	80mm	100mm	150mm
重量 Weight	198kg	198kg	290kg	490kg
推荐前级泵 Remmend backing pump models	PNK SP 0063	PNK SP 0100	PNK SP 0250/0300	PNK MT0600T PNK SP 0100

	PNK MR 4300T	PNK MR 9000T	PNK MR 18000T	PNK MR 36000T
额定流量 Rated airflow	4300m <sup>3</sup> /h	9000m <sup>3</sup> /h	18000m <sup>3</sup> /h	36000m <sup>3</sup> /h
	1200L/S	2500L/S	5000L/S	10000L/S
极限压力 Ultimate pressure	≤0.05pa	≤0.05pa	≤0.05pa	≤0.05pa
最大允许压差 Max.Differential pressure	≥6×10 <sup>3</sup> pa	≥5×10 <sup>3</sup> pa	≥4×10 <sup>3</sup> pa	≥3×10 <sup>3</sup> pa
电机功率 Motor power	11kw	18.5kw	37kw	55kw
转速 Nominal speed	2900rpm	2900rpm	1450rpm	1450rpm
进气口 Suction	250mm	320mm	400mm	500mm
排气口 Discharge	200mm	250mm	320mm	400mm
重量 Weight	790kg	1550kg	3080kg	5000kg
推荐前级泵 Remmend backing pump models	PNK MT1100T PNK SP 0250	PNK MT2200T PNK SP 0630	PNK MT4300T PNK SP 0630	PNK MT4300T PNK SP 0630

# 罗茨真空泵

## ROOTS TYPE MECHANICAL BOOSTER PUMPS

### 性能曲线

PNK MR 0300T

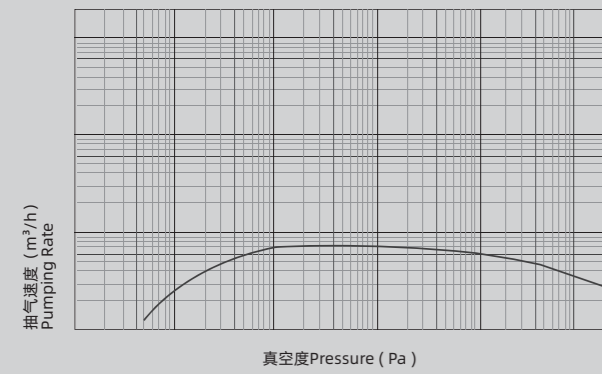

PNK MR 0600T

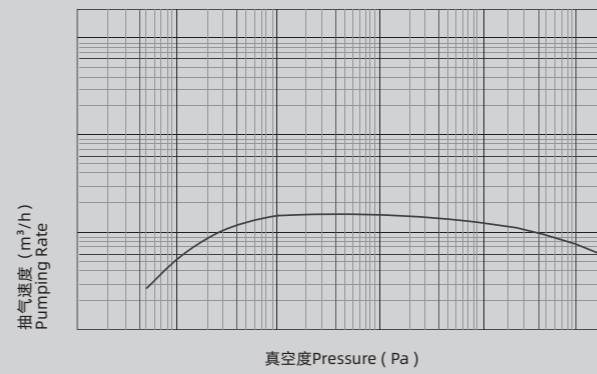

PNK MR 4300T

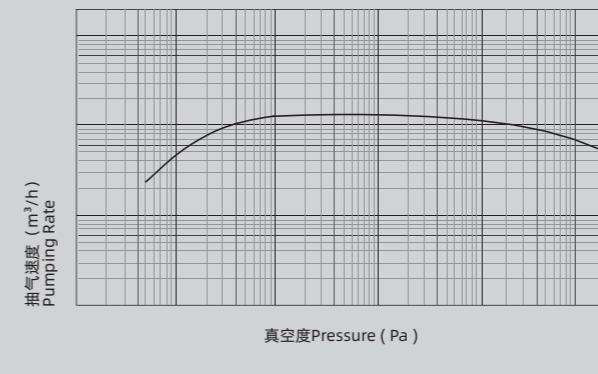

PNK MR 9000T

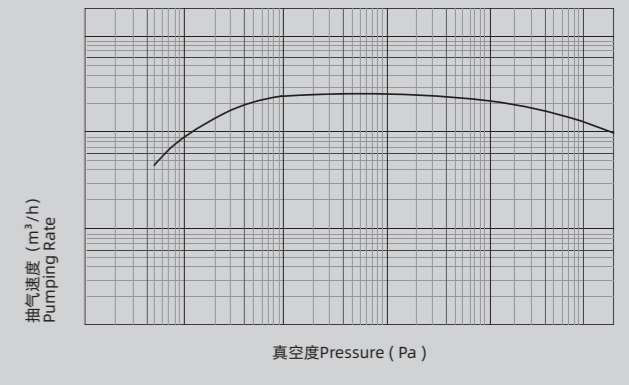

PNK MR 1100T

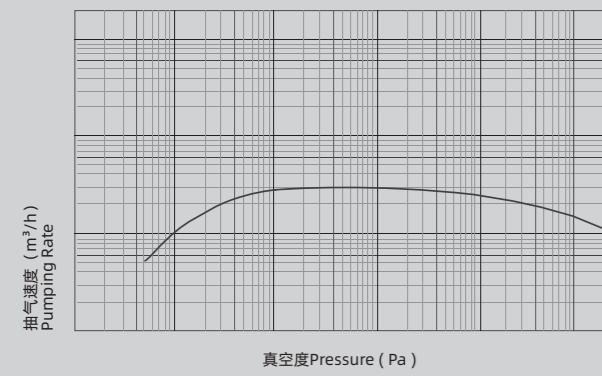

PNK MR 2200T

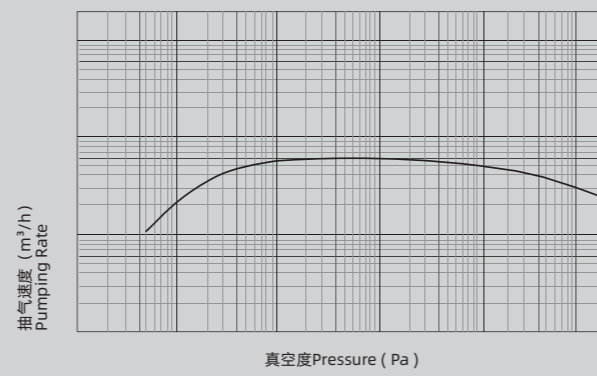

PNK MR 18000T

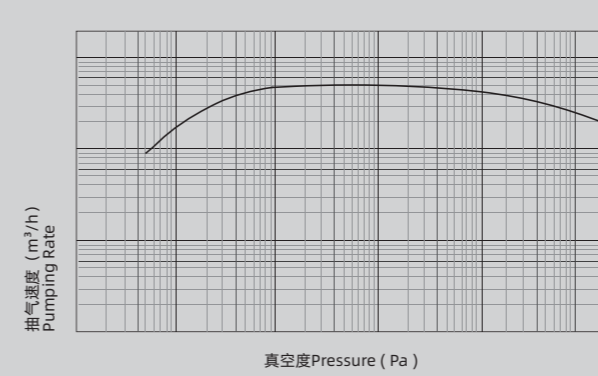

PNK MR 36000T

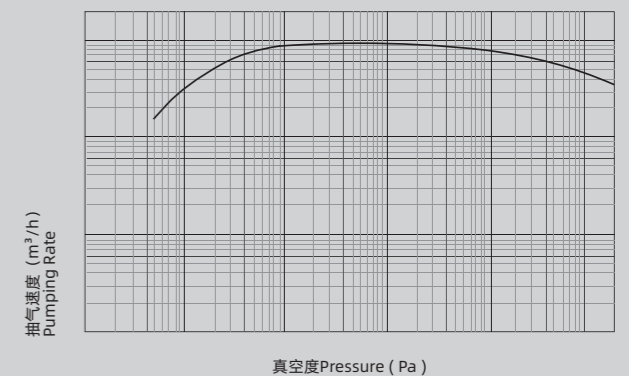

# 罗茨真空泵

## ROOTS TYPE MECHANICAL BOOSTER PUMPS

### 安装尺寸

PNK MR 0300T

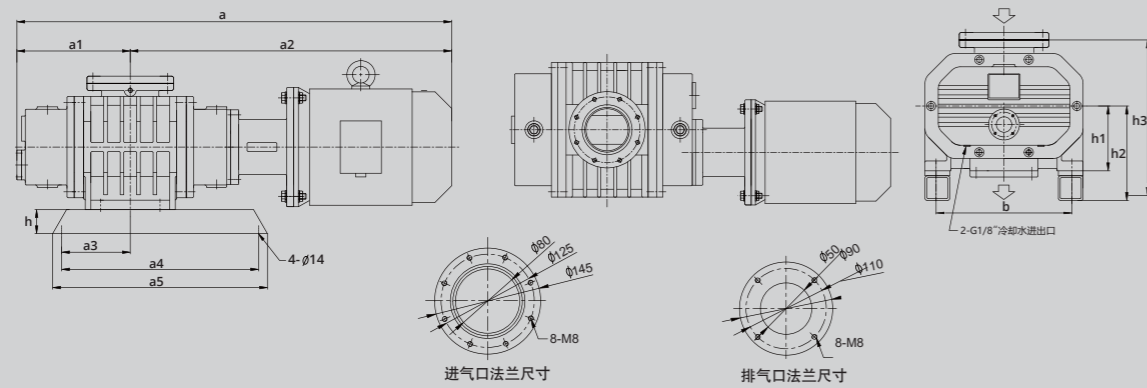

TYPE	a	a1	a2	a3	a4	a5	b	h	h1	h2	h3
PNK MR 0300T	729	190	539	115	330	360	220	40	105	153	252

PNK MR 1100T

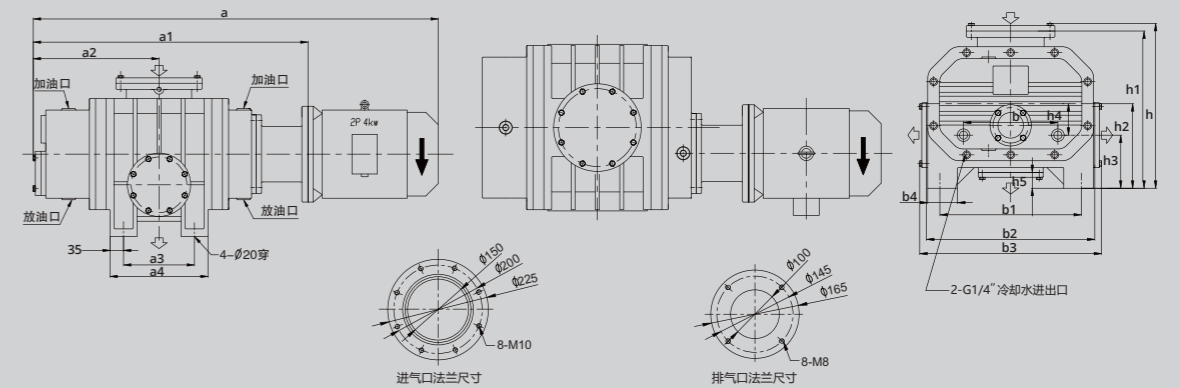

TYPE	a	a1	a2	a3	a4	b	b1	b2	b3	b4	h	h1	h2	h3	h4	h5
PNK MR 1100T	1056	716	190	185	255	240	360	428	463	76	419	400	215	135	80	40

PNK MR 0600T

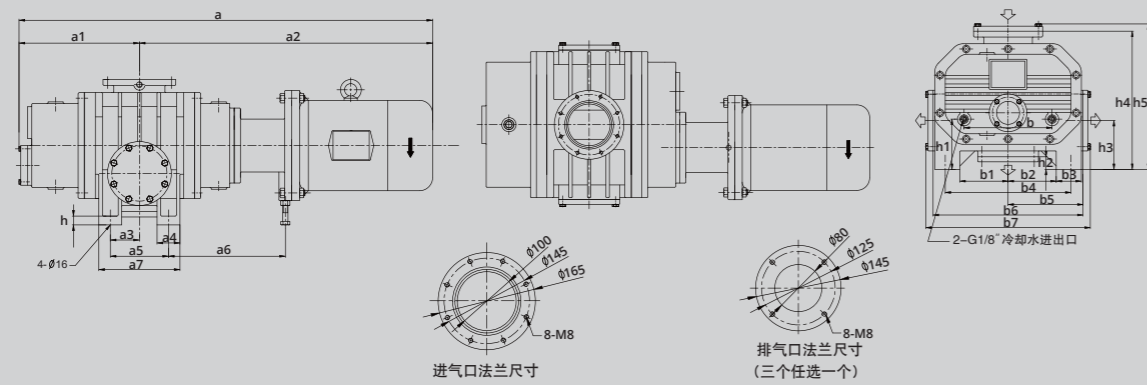

TYPE	a	a1	a2	a3	a4	a5	a6	a7	b	b1	b2	b3	b4	b5	b6	b7	h	h1	h2	h3	h4	h5
PNK MR 0600T	938	273	66	66	52	152	172	345	2210	115	115	60	300	179	358	392	20	120	30	116.5	330	347

PNK MR 2200T

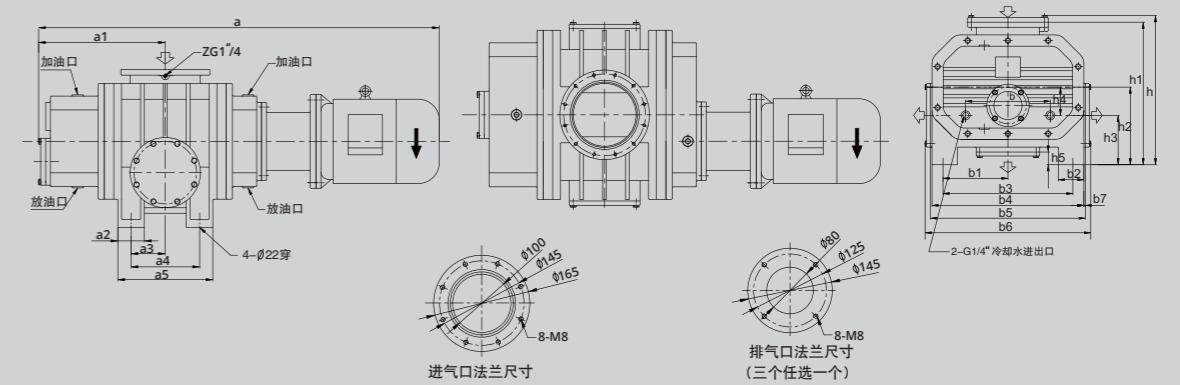

TYPE	a	a1	a2	a3	a4	a5	b	b1	b2	b3	b4	b5	b6	b7	h	h1	h2	h3	h4	h5
PNK MR 2200T	1282	405	85	110	220	304	300	230	90	460	538	548	587	5	528	505	275	175	100	45

# 罗茨真空泵

## ROOTS TYPE MECHANICAL BOOSTER PUMPS

### 安装尺寸

PNK MR 4300T

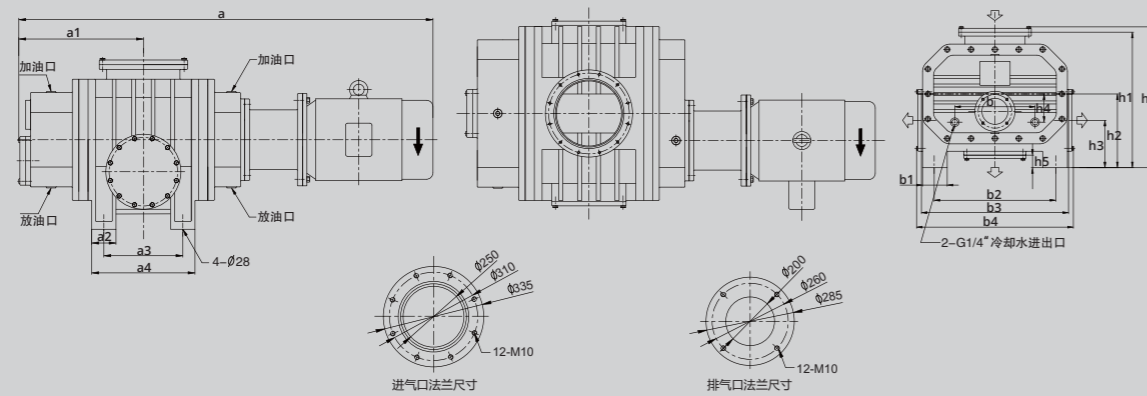

TYPE	a	a1	a2	a3	a4	b	b1	b2	b3	b4	h	h1	h2	h3	h4	h5
PNK MR 4300T	1573	473	92	300	392	370	114	560	678	722.8	469.4	625	340	218.5	130	58

PNK MR 18000T

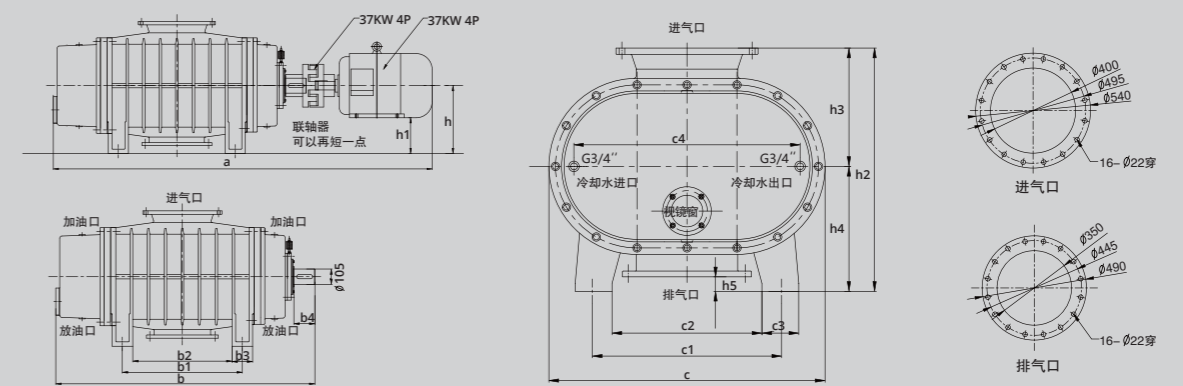

TYPE	a	b	b1	b2	b3	b4	c	c1	c2	c3	h	h1	h2	h3	h4	h5
PNK MR 18000T	2653.53	1770	820	678	141	143.5	1050	720	570	140	469.4	625	925	450	475	55

PNK MR 9000T

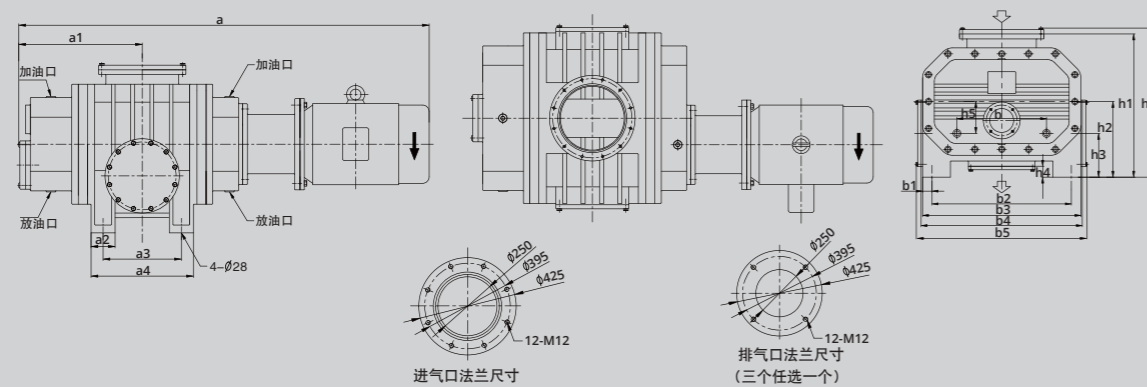

TYPE	a	a1	a2	a3	a4	b	b1	b2	b3	b4	b5	h	h1	h2	h3	h4	h5
PNK MR 9000T	1890	594	112	440	552	450	48	700	796	810	858.5	749.5	720	380	220	55	160

PNK MR 36000T

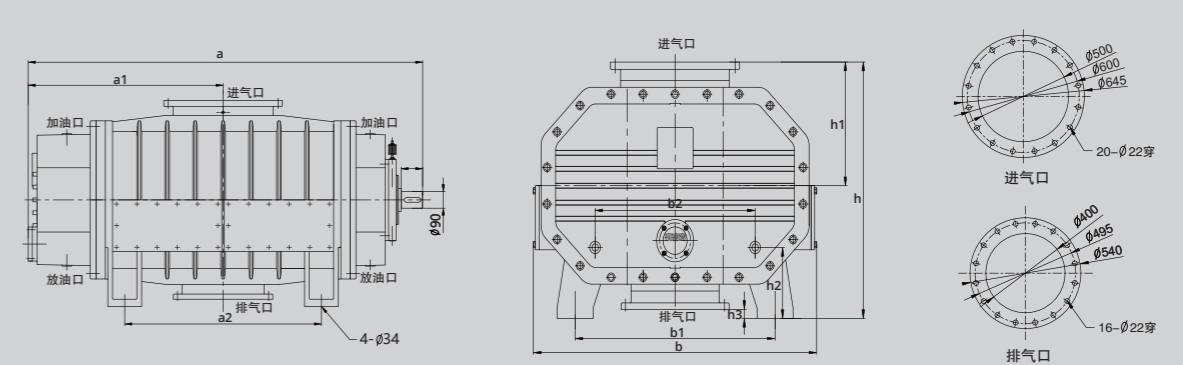

TYPE	a	a1	a2	b	b1	b2	h	h1	h2	h3
PNK MR 36000T	2144	1059	1070	1416	1000	800	1120	540	310	40

# 干式螺杆真空泵

洁净无油，真空极限好，适用范围广

DRY SCREW VACUUM PUMPS

PNK DSP SERIES



## 特性和优点

PRONOTEK干式螺杆泵新系列的泵适用于与中低真空有关的应用。该产品线专为工业和镀膜应用而设计。在需要无油真空的领域，PNK DSP系列螺杆真空泵是完美的解决方案。该系列产品的抽速在100到630m<sup>3</sup>/h之间。

- 抽速在100到630m<sup>3</sup>/h之间全系列的泵
- 最佳极限真空和广范围的应用
- 绝对干燥和无油
- 大气压下的高抽速减少了抽空时间
- 带有温度监控的水冷却
- 得益于高效内部压缩而实现的较低能源成本
- 动态无磨损的密封件
- 直接气流和优化的温度曲线使沉积最小化
- 低能耗、低噪音
- 多种配件

## 应用领域

- 冶金
- 镀膜
- 冷冻干燥
- 电子束焊接
- 气体分离

# 干式螺杆真空泵

DRY TYPE

SCREW VACUUM PUMPS

## 规格参数

	Unit	PNK DSP 0060	PNK DSP 0100	PNK DSP 0180
额定流量 Rated airflow	m <sup>3</sup> /h	60	96	180
	m <sup>3</sup> /min	1	1.6	3
	L/S	16.7	26.7	50
极限压力 Ultimate pressure	Mbar	1.0 × 10 <sup>-2</sup>	1.0 × 10 <sup>-2</sup>	1.0 × 10 <sup>-2</sup>
	Torr	7.50 × 10 <sup>-2</sup>	7.50 × 10 <sup>-2</sup>	7.50 × 10 <sup>-2</sup>
	Pa	1	1	1
电机功率 Motor power	Kw	2.2	3.7	5.5
转子转速 Rotor speed	RPM	2900/3500	2900/3500	2900/3500
噪音 Sound	db	72	72	73
吸气口 Gas Inlet	mm	25	40	65
排气口 Discharge	mm	25	40	50
冷却水量 Cooling Water	L/min	0-10	0-10	0-10
空温 Air Temperature	℃	0-50	0-50	0-50
操作湿度 Operation moisture	/	90%	90%	90%

	Unit	PNK DSP 0270	PNK DSP 0360	PNK DSP 0460
额定流量 Rated airflow	m <sup>3</sup> /h	270	348	456
	m <sup>3</sup> /min	4.5	5.8	7.6
	L/S	75	97	127
极限压力 Ultimate pressure	Mbar	1.0 × 10 <sup>-2</sup>	1.0 × 10 <sup>-2</sup>	1.0 × 10 <sup>-2</sup>
	Torr	7.50 × 10 <sup>-2</sup>	7.50 × 10 <sup>-2</sup>	7.50 × 10 <sup>-2</sup>
	Pa	1	1	1
电机功率 Motor power	Kw	7.5	11	15
转子转速 Rotor speed	RPM	2900/3500	2900/3500	2900/3500
噪音 Sound	db	75	75	75
吸气口 Gas Inlet	mm	65	65	80
排气口 Discharge	mm	50	50	65
冷却水量 Cooling Water	L/min	10-15	10-15	15-20
空温 Air Temperature	℃	0-50	0-50	0-50
操作湿度 Operation moisture	/	90%	90%	90%



# 干式螺杆真空泵

DRY TYPE  
SCREW VACUUM PUMPS

## 规格参数

	Unit	PNK DSP 0600	PNK DSP 0750	PNK DSP 0960
额定流量 Rated airflow	m <sup>3</sup> /h	600	720	960
	m <sup>3</sup> /min	10	12	16
	L/S	167	200	267
极限压力 Ultimate pressure	Mbar	1.0 × 10 <sup>-2</sup>	1.0 × 10 <sup>-2</sup>	1.0 × 10 <sup>-2</sup>
	Torr	7.50 × 10 <sup>-2</sup>	7.50 × 10 <sup>-2</sup>	7.50 × 10 <sup>-2</sup>
	Pa	1	1	1
电机功率 Motor power	Kw	18.5	22	30
转子转速 Rotor speed	RPM	2900/3500	2900/3500	2900/3500
噪音 Sound	db	78	78	85
吸气口 Gas Inlet	mm	100	100	100
排气口 Discharge	mm	65	80	80
冷却水量 Cooling Water	L/min	15-20	15-20	30-40
空温 Air Temperature	℃	0-50	0-50	0-50
操作湿度 Operation moisture	/	90%	90%	90%

# 干式螺杆真空泵

DRY TYPE  
SCREW VACUUM PUMPS

## 性能曲线

PNK DSP 0060

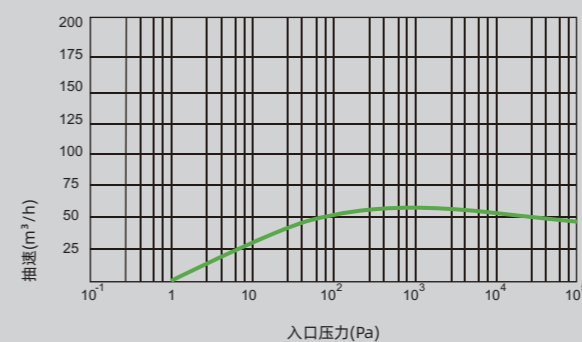

PNK DSP 0100

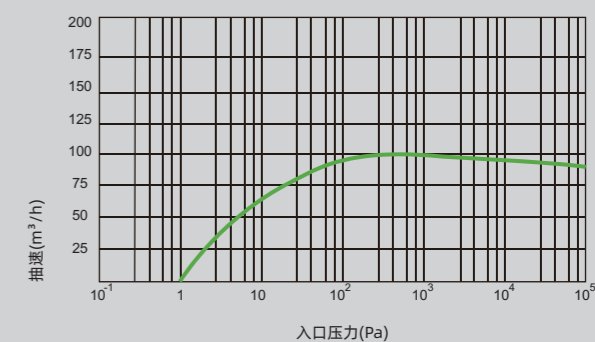

PNK DSP 0180

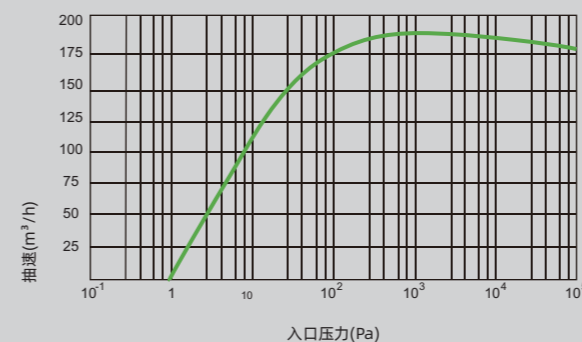

PNK DSP 0270

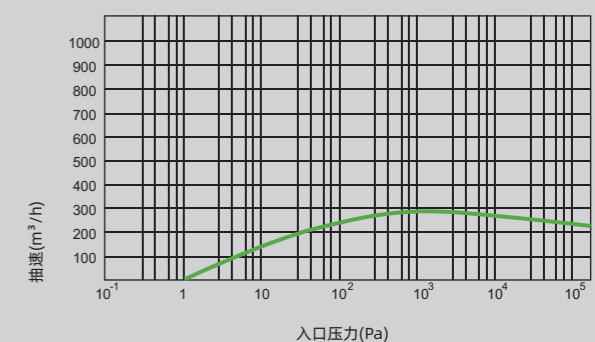

PNK DSP 0360

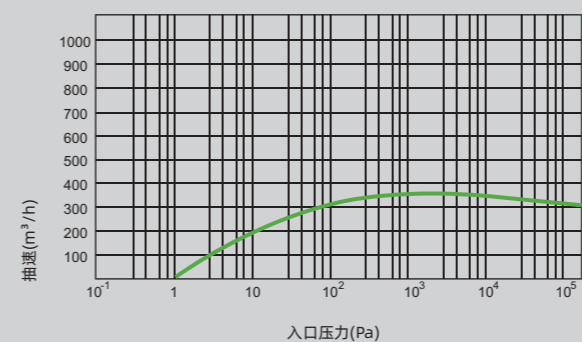

PNK DSP 0460

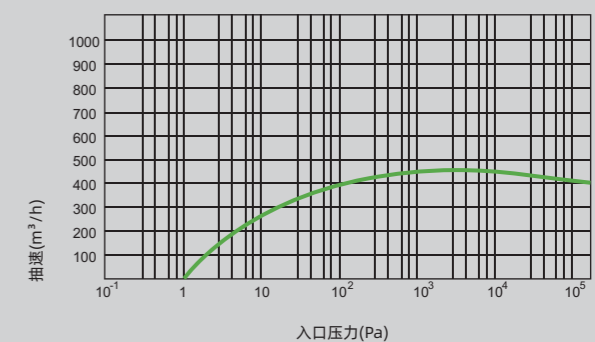

# 干式螺杆真空泵

DRY TYPE  
SCREW VACUUM PUMPS

## 性能曲线

PNK DSP 0600

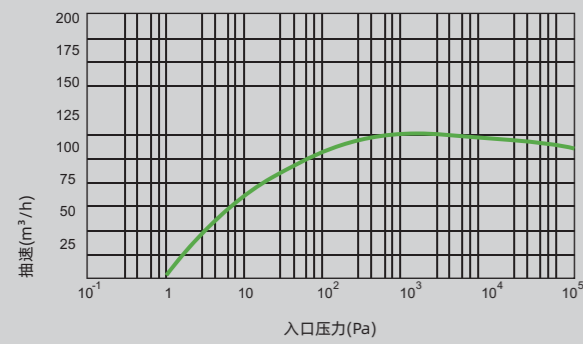

PNK DSP 0750

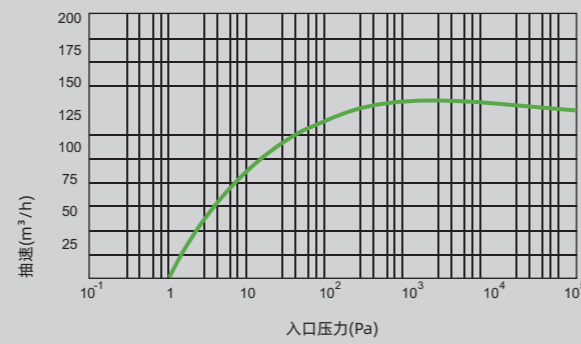

PNK DSP 0960

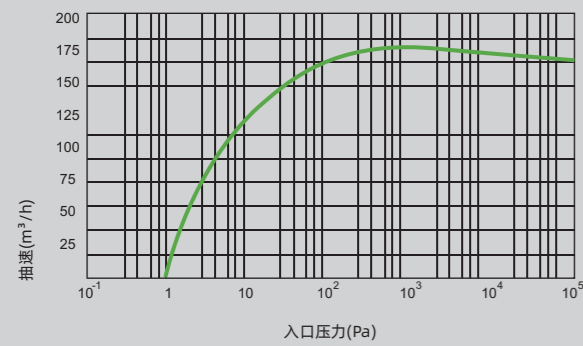

# 干式螺杆真空泵

DRY TYPE  
SCREW VACUUM PUMPS

## 安装尺寸

PNK DSP 0060

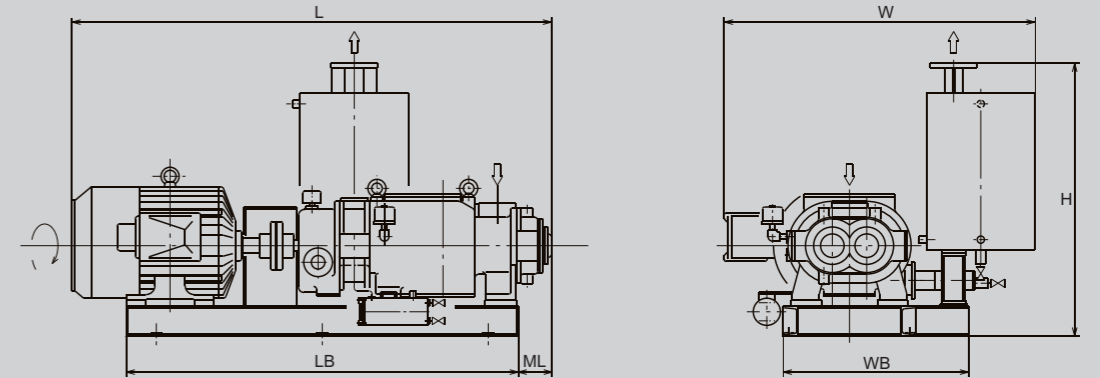

TYPE	L	LB	ML	W	WB	H
PNK DP 048D	1020	750	76	630	470	765

PNK DSP 0100

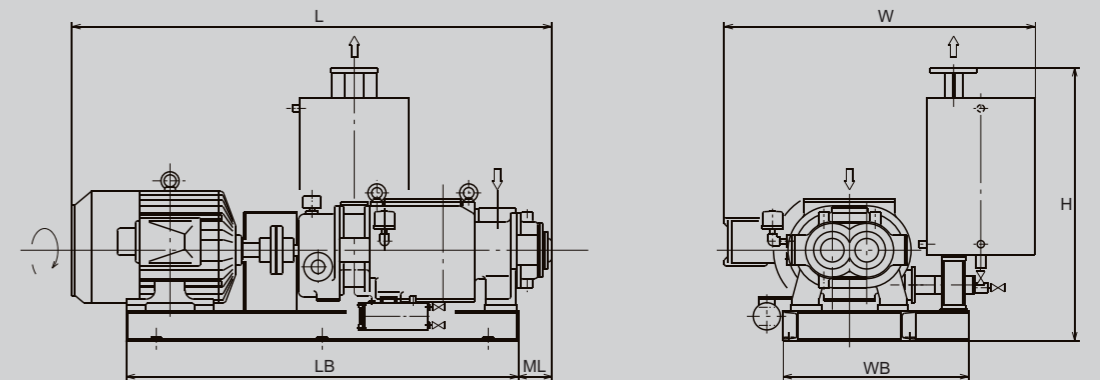

TYPE	L	LB	ML	W	WB	H
PNK DSP 0100	1159	900	80	680	490	780

# 干式螺杆真空泵

DRY TYPE  
SCREW VACUUM PUMPS

## 安装尺寸

PNK DSP 0180

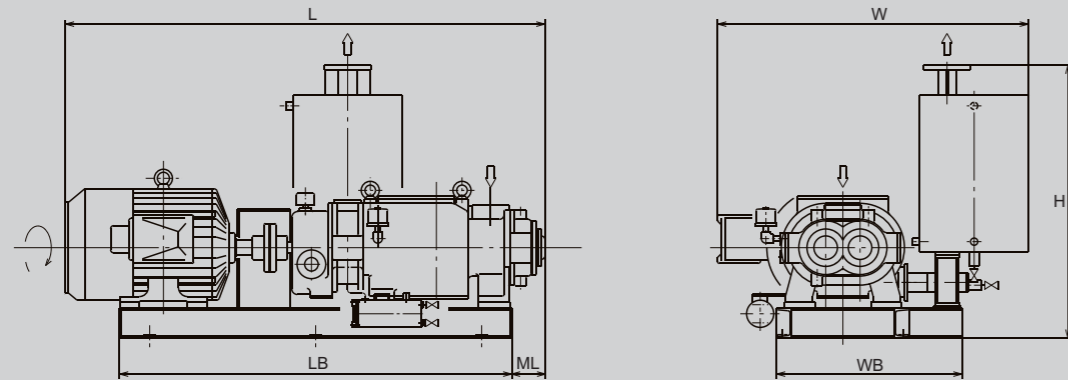

TYPE	L	LB	ML	W	WB	H
PNK DSP 0180	1270	1000	83	720	550	805

PNK DSP 0360

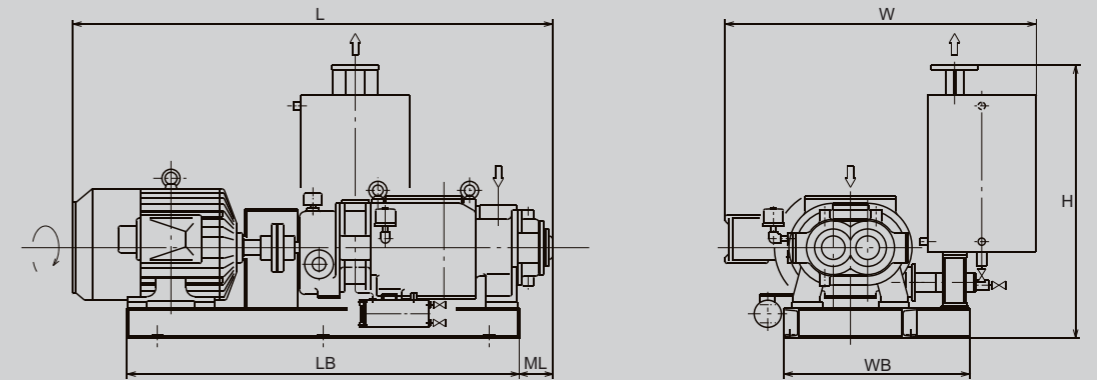

TYPE	L	LB	ML	W	WB	H
PNK DSP 0360	1430	1200	88	840	620	905

PNK DSP 0270

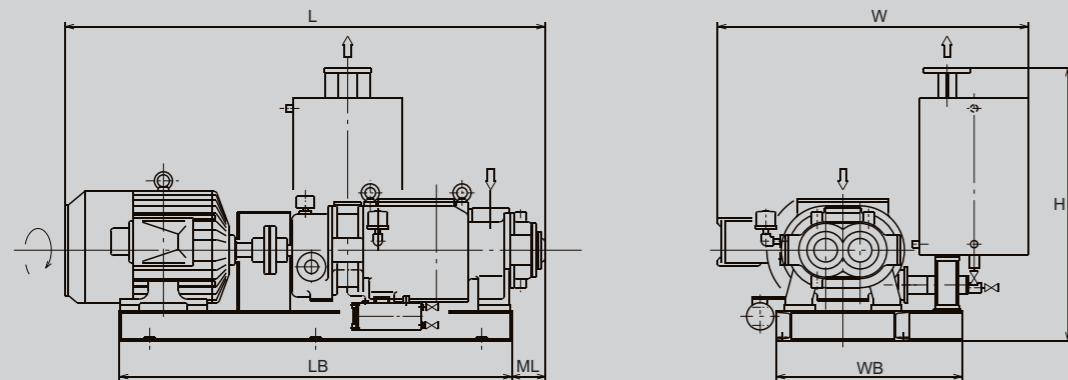

TYPE	L	LB	ML	W	WB	H
PNK DSP 0270	1370	1100	85	760	600	850

PNK DSP 0460

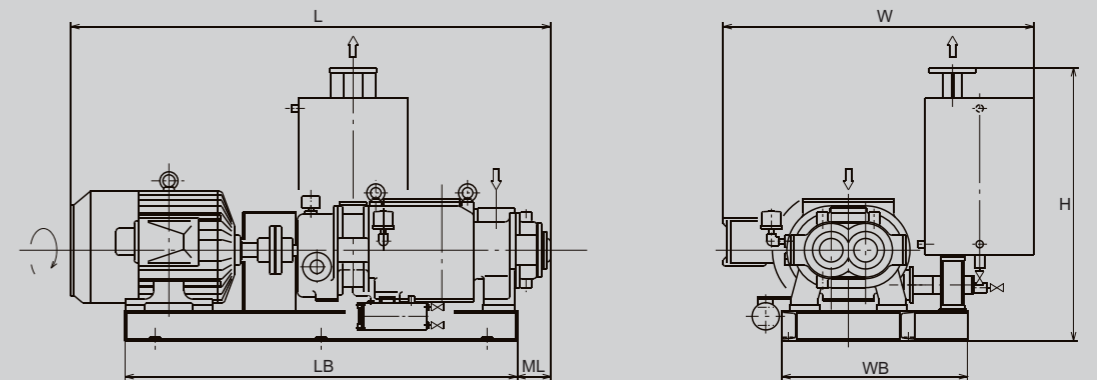

TYPE	L	LB	ML	W	WB	H
PNK DSP 0460	1550	1300	95	860	645	940

# 干式螺杆真空泵

DRY TYPE  
SCREW VACUUM PUMPS

## 安装尺寸

PNK DSP 0600

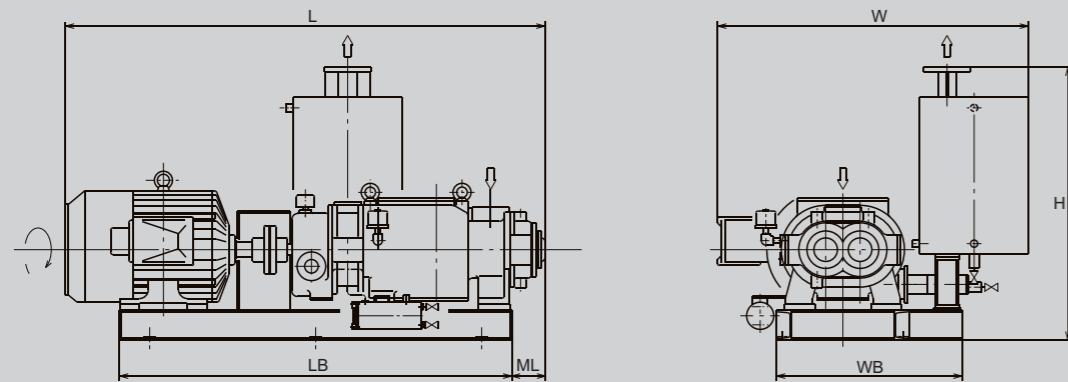

TYPE	L	LB	ML	W	WB	H
PNK DSP 0600	1730	1500	107	900	675	960

PNK DSP 0960

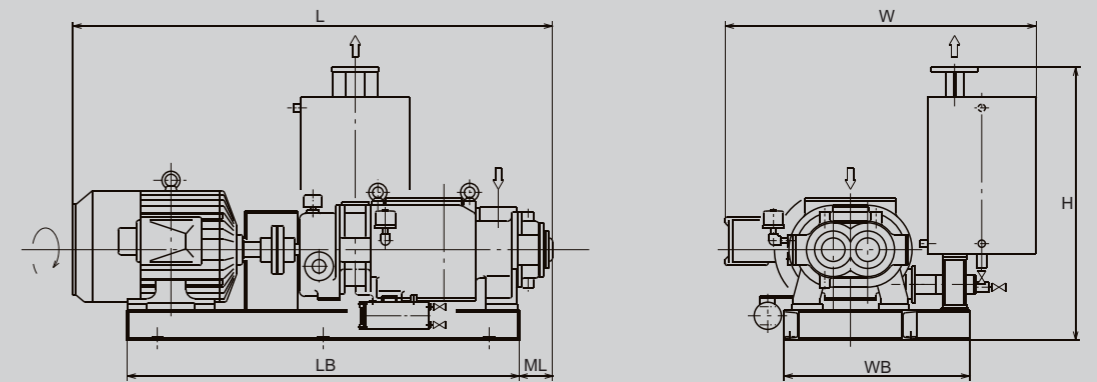

TYPE	L	LB	ML	W	WB	H
PNK DSP 0960	1950	1700	131	1000	750	1010

PNK DSP 0750

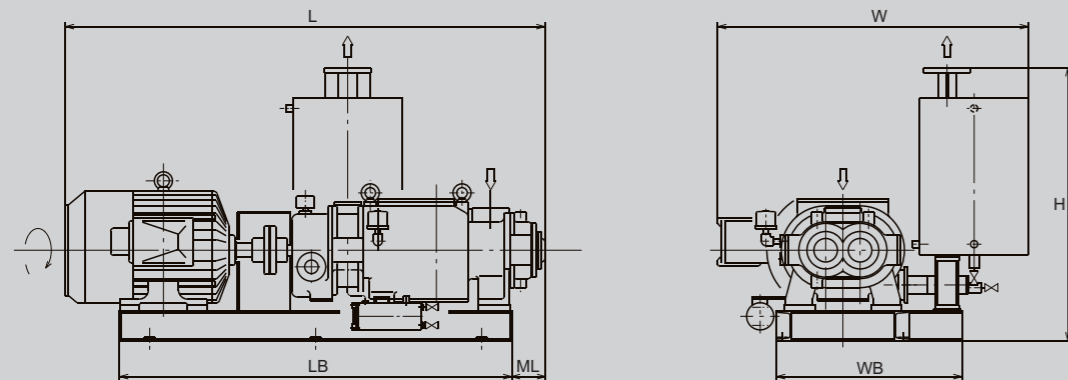

TYPE	L	LB	ML	W	WB	H
PNK DSP 0750	1873	1600	118	960	730	986

# 无油碳片真空泵

洁净无油，真空极限好，适用范围广

OIL FREE ROTARY VANE PUMPS

PNK CRP-SERIES

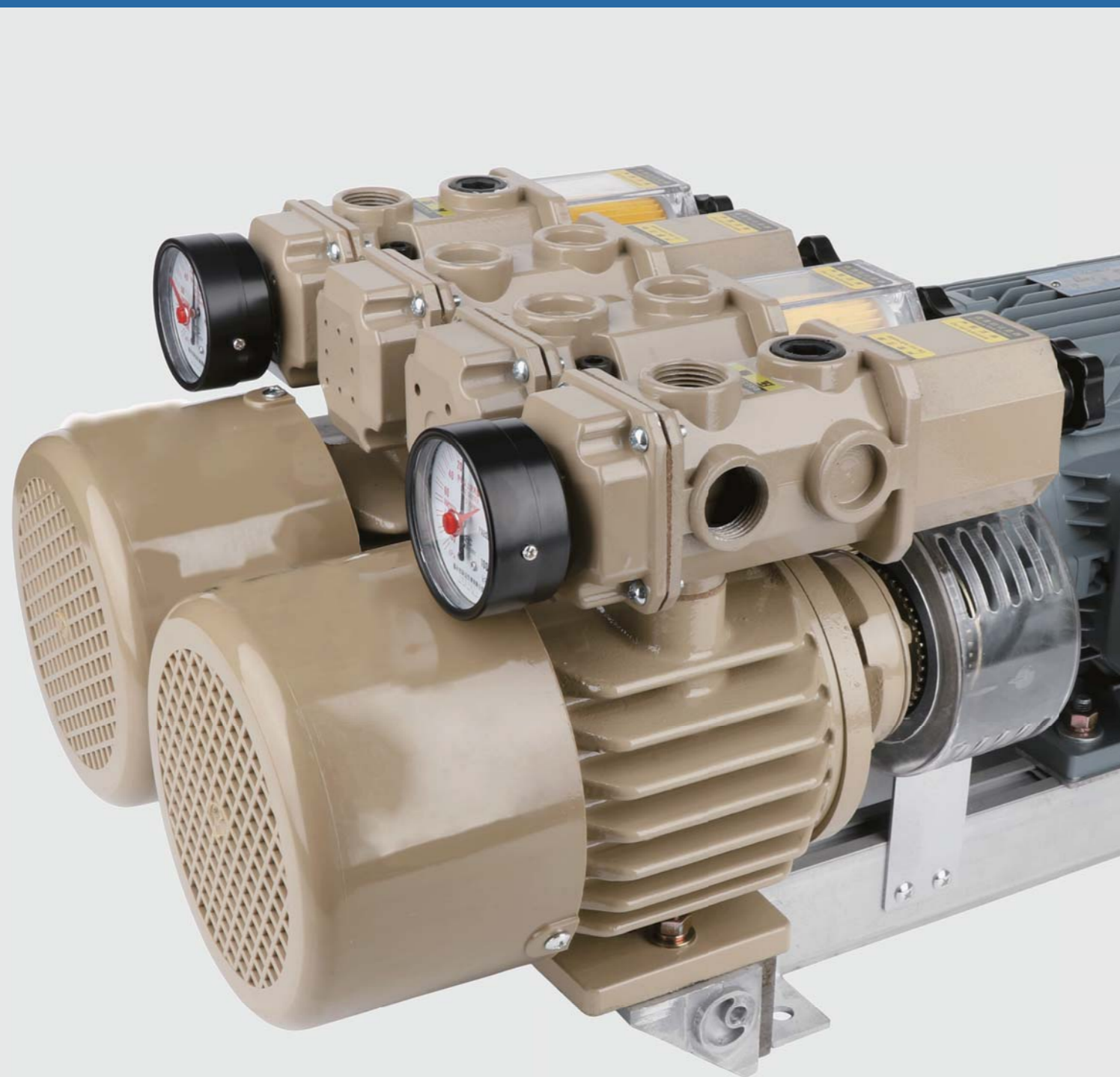

## 特性和优点

Pronotek CRP系列无油旋片式真空泵因其无油无污染，免维护，高极限真空、高抽取速度、运行噪音小而享有盛誉。

### ■ 无油无污染

无论使用在真空、排气的场合也不含油分，不会对应用环境造成任何污染

### ■ 免维护

不需要给泵加油，不需要维护和检修

### ■ 性能

长期无故障 - 运行噪音低，原机装配真空压力表和调压控制器

### ■ 再保证

安心 - 经过多年尝试、测试，已经成为工业标准可靠且稳定

## 应用领域

- 真空升降机、真空吸盘
- 印刷机，装订机、真空成型机
- 标签粘贴机、医疗设备
- 机械臂

# 无油碳片真空泵

OIL FREE  
ROTARY VANE PUMPS

## 规格参数

	PNK CRP 30	PNK CRP 50	PNK CRP 80	PNK CRP120
转速 Speed	1430rpm	1430rpm	1430rpm	1430rpm
设计排气量 Desigened Pumping Capacity	480 L/min	810 L/min	1150 L/min	1500L/min
常用真空度 Contionous Operative Vacuum	60 kpa	60 kpa	60 kpa	60 kpa
常用排气压力 Contionous Operative Perssure	60 kpa	60 kpa	60 kpa	60 kpa
配管接口 Sucation Exhaust Port Diameter	RC3/4	RC3/4	RC3/4	RC1
电源 Motor Voltage	200/380 V (三相)	200/380 V (三相)	200/380 V (三相)	200/380 V (三相)
电机功率 Motor power	0.75 Kw	1.5 Kw	2.2 Kw	4.0 Kw
重量 Weight	41 Kg	53 Kg	78 Kg	120 Kg

	PNK CRP S15	PNK CRP S25	PNK CRP S40	PNK CRPS60
转速 Speed	1430rpm	1430rpm	1430rpm	1430rpm
设计排气量 Desigened Pumping Capacity	280 L/min	405 L/min	575 L/min	700 L/min
到达真空度 Contionous Operative Vacuum	84 kpa	86 kpa	86 kpa	90 kpa
常用真空度 Contionous Operative Vacuum	60 kpa	60 kpa	60 kpa	60 kpa
常用排气压力 Contionous Operative Perssure	60 kpa	60 kpa	60 kpa	60 kpa
配管接口 Sucation Exhaust Port Diameter	RC3/4	RC3/4	RC3/4	RC1
电源 Motor Voltage	1Φ100-220/3Φ200/380	200-380(三相)	200-380(三相)	200-380(三相)
电机功率 Motor power	0.4/0.37 Kw	0.75/0.75 Kw	1.5 Kw	2.2 Kw
重量 Weight	25 Kg	33 Kg	50 Kg	70 Kg

1) 可根据需求定制特殊电压或马达

# 无油碳片真空泵

OIL FREE  
ROTARY VANE PUMPS

## 性能曲线

PNK CRP 30

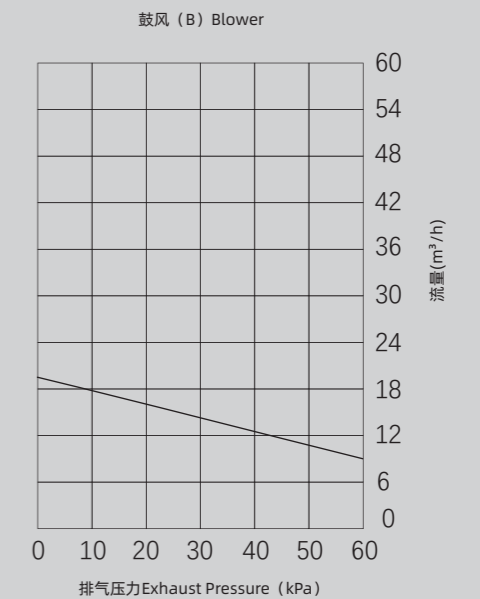
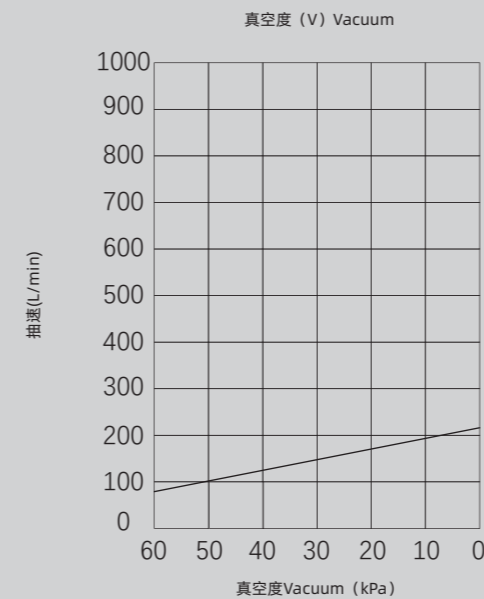

PNK CRP 50

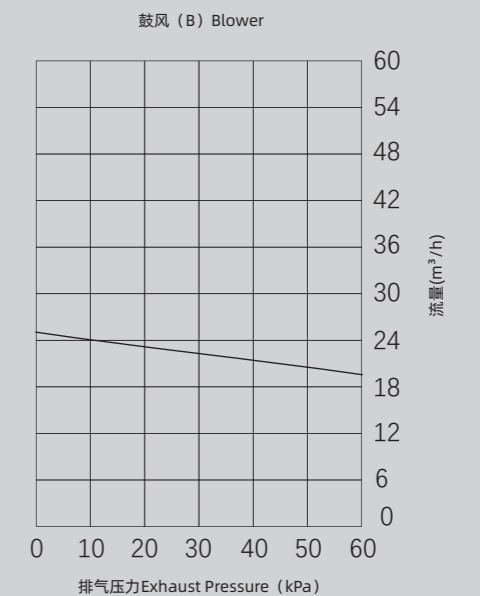
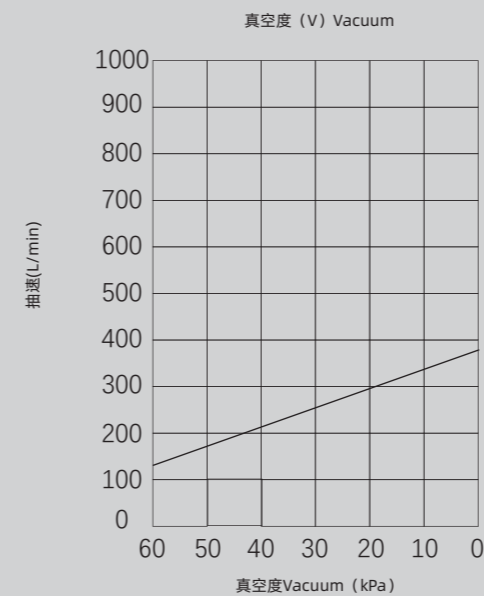

# 无油碳片真空泵

OIL FREE  
ROTARY VANE PUMPS

## 性能曲线

PNK CRP 80

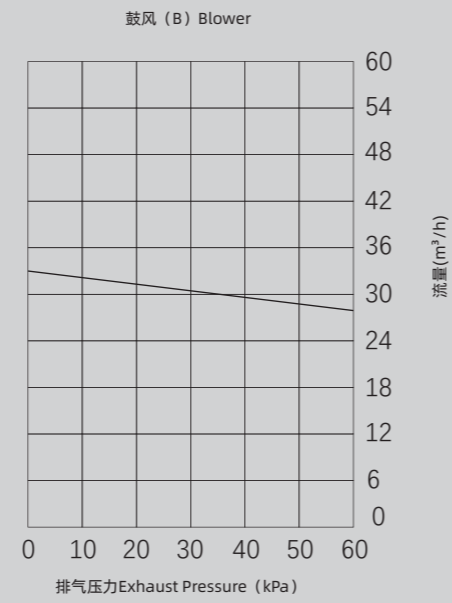
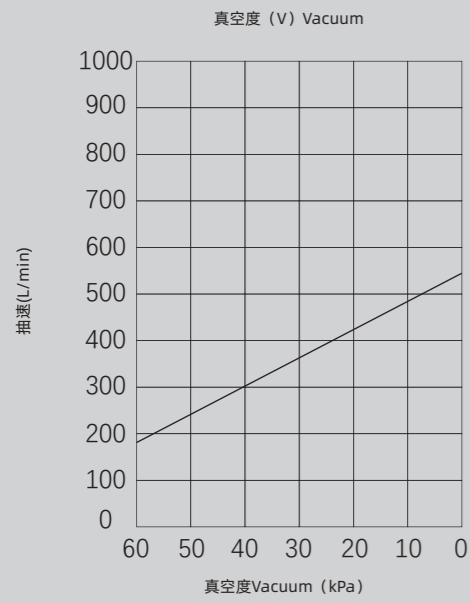

PNK CRP S15

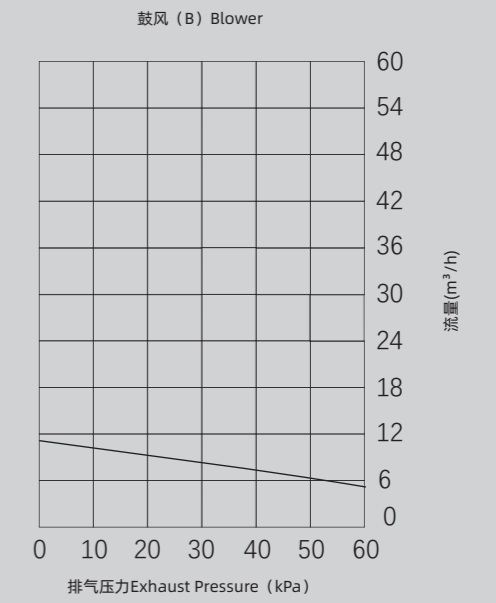
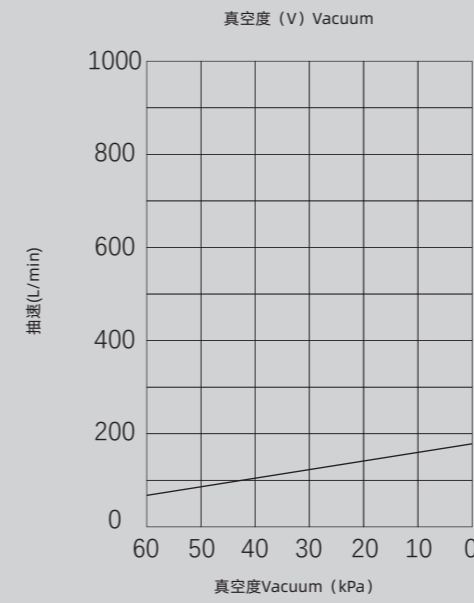

PNK CRP 120

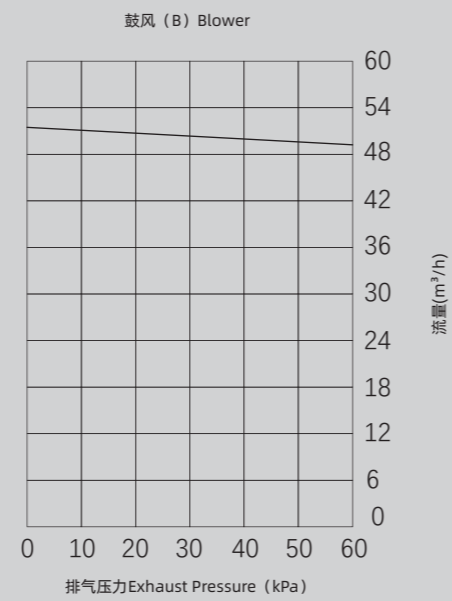
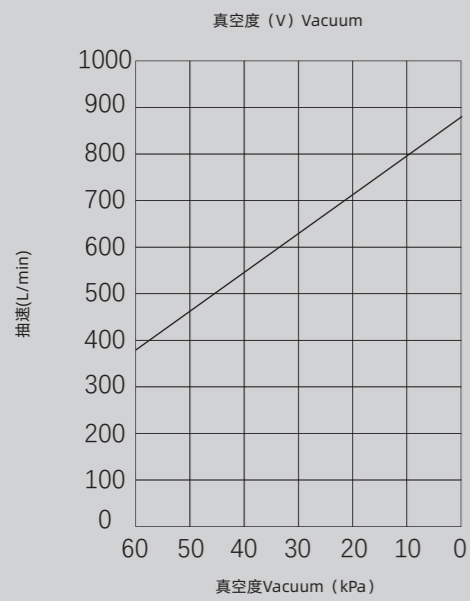

PNK CRP S25

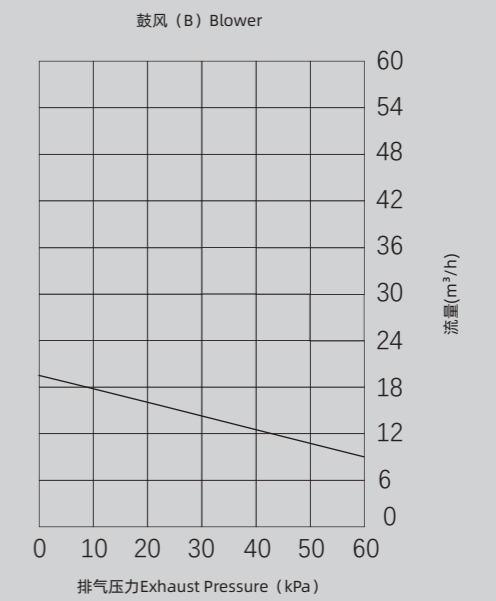
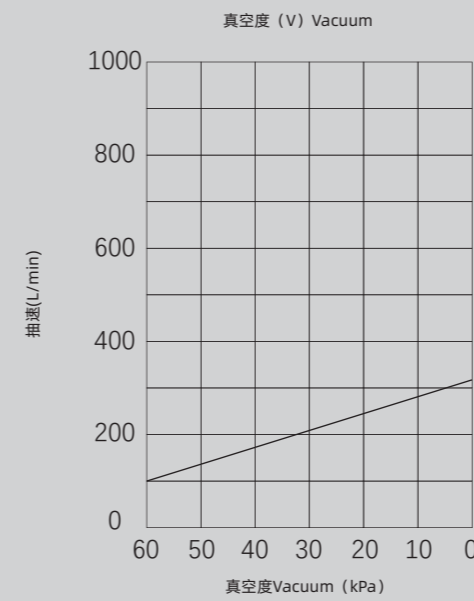

# 无油碳片真空泵

OIL FREE  
ROTARY VANE PUMPS

## 性能曲线

PNK CRP S40

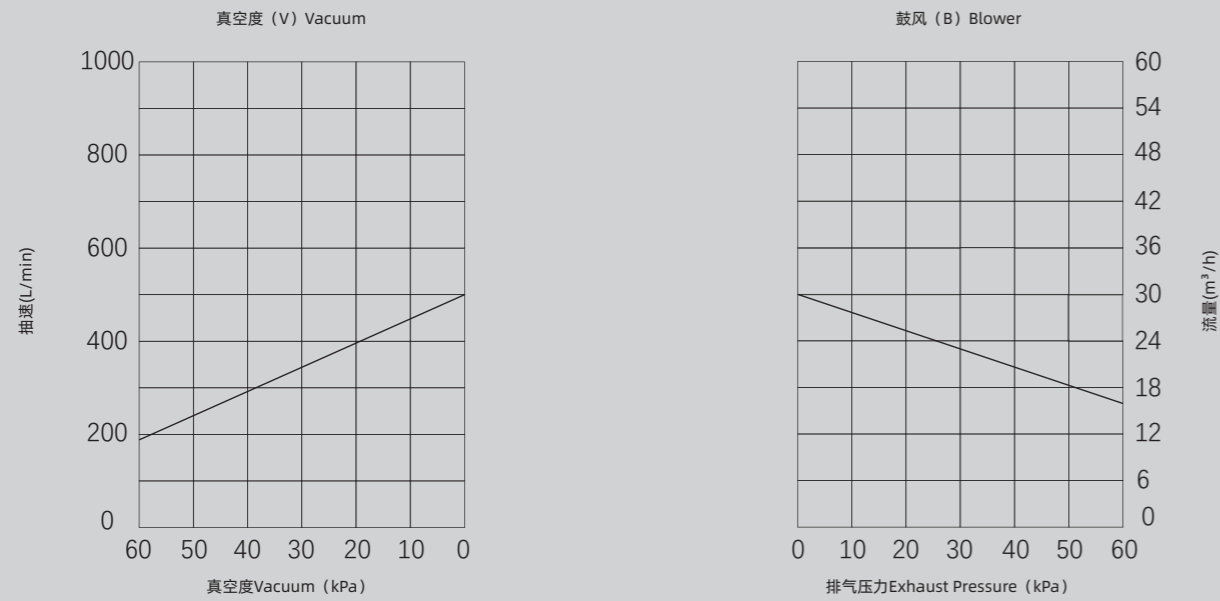

PNK CRP S60

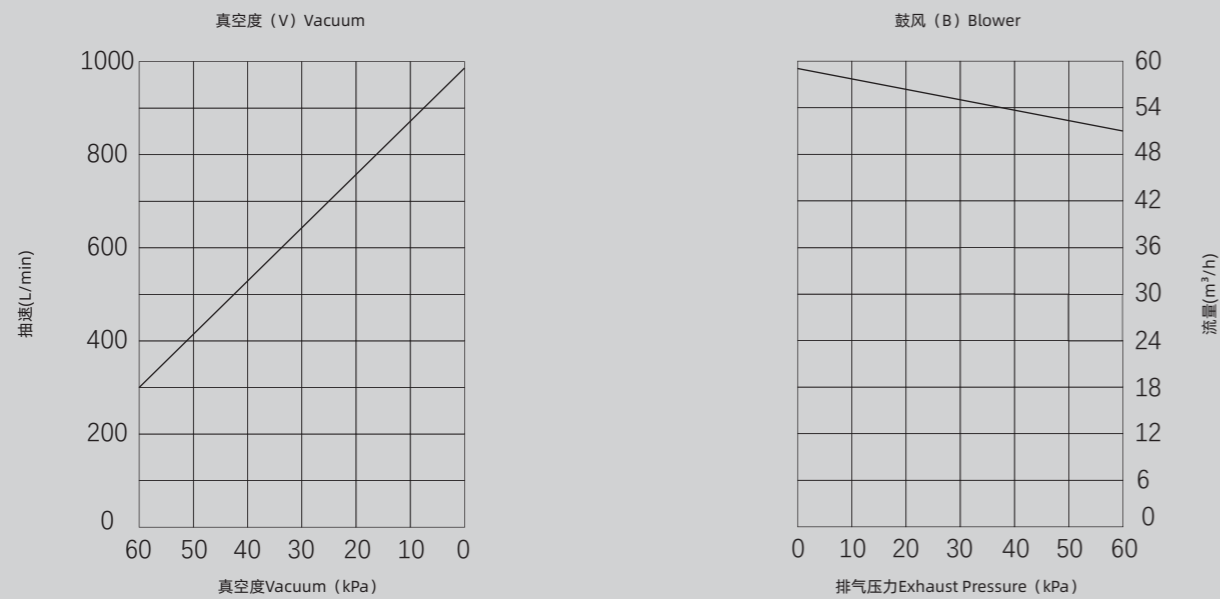

# 无油碳片真空泵

OIL FREE  
ROTARY VANE PUMPS

## 安装尺寸

PNK CRP 30

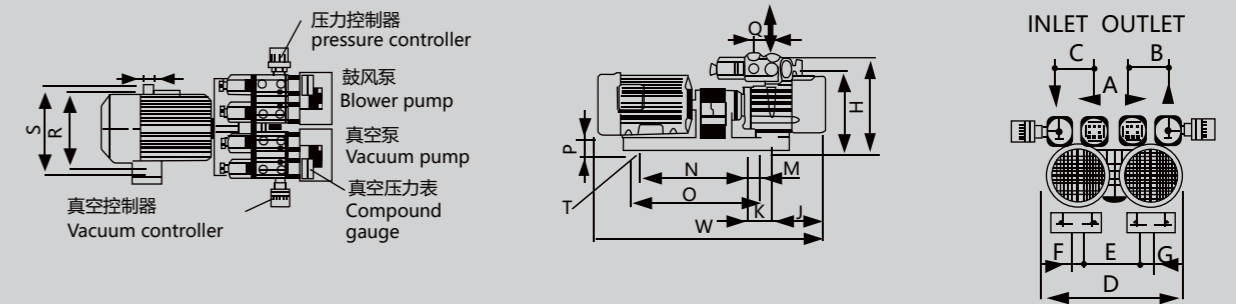

TYPE	H	D	W	A	B	C	E	F	G	I	J	K
PNK CRP 30	269	324	473.5	170	90	90	97	28	28	229.5	107	65

TYPE	L	M	N	O	P	Q	R	S	T
PNK CRP 30	30	35.5	225	280.5	50	50	205	233	4-Φ9

PNK CRP 50

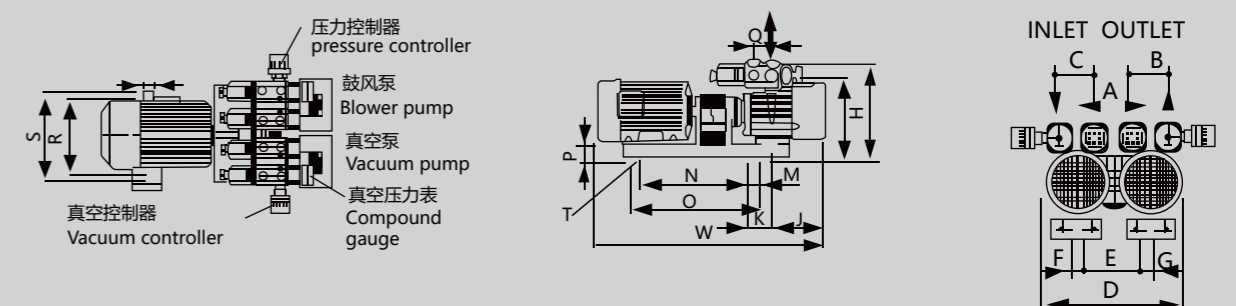

TYPE	H	D	W	A	B	C	E	F	G	I	J	K
PNK CRP 50	272	329	553	170	90	90	112	28	28	231.5	127	65

TYPE	L	M	N	O	P	Q	R	S	T
PNK CRP 50	30	35.5	270	325.5	50	50	220	248	4-Φ9



# 无油碳片真空泵

## OIL FREE ROTARY VANE PUMPS

### 安装尺寸

PNK CRP 80

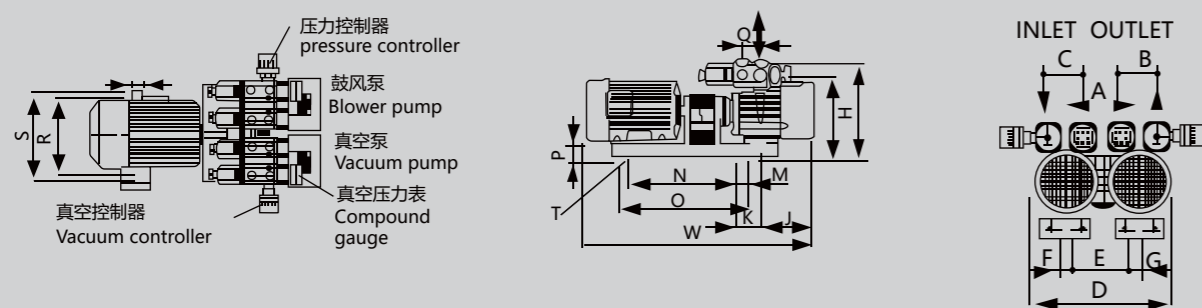

TYPE	H	D	W	A	B	C	E	F	G	I	J	K
PNK CRP 80	288	334	648	170	90	90	112	28	28	248.5	152	75

TYPE	L	M	N	O	P	Q	R	S	T
PNK CRP 80	30	35.5	305	380.5	50	50	240	268	4-Φ9

PNK CRP S15

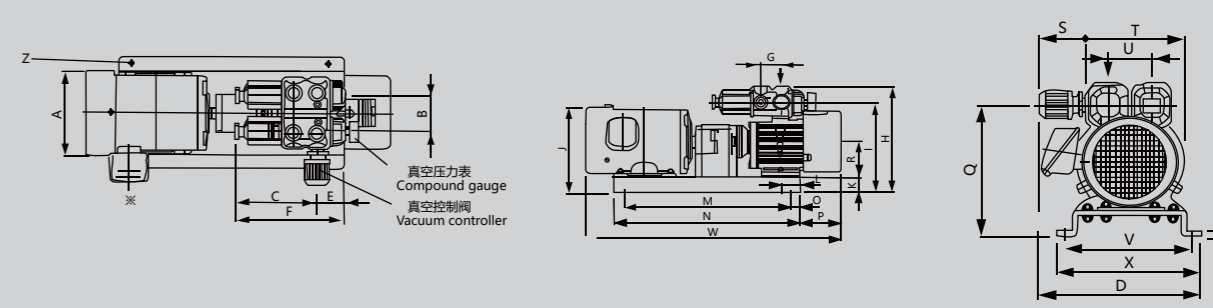

TYPE	H	D	W	A	B	C	E	F	G	I	J	K
PNK CRP S15	248(257)	270	468(482)	Φ144 (Φ137)	80	135	42	177	92	208(217)	178(172)	32

TYPE	L	M	N	O	P	Q	R	S	T	U	V	X	Y	Z
PNK CRP S15	30	304	364	30	77	210.5 (219.5)	71	78	154	90	205	230	4.5	4-Φ9

PNK CRP 120

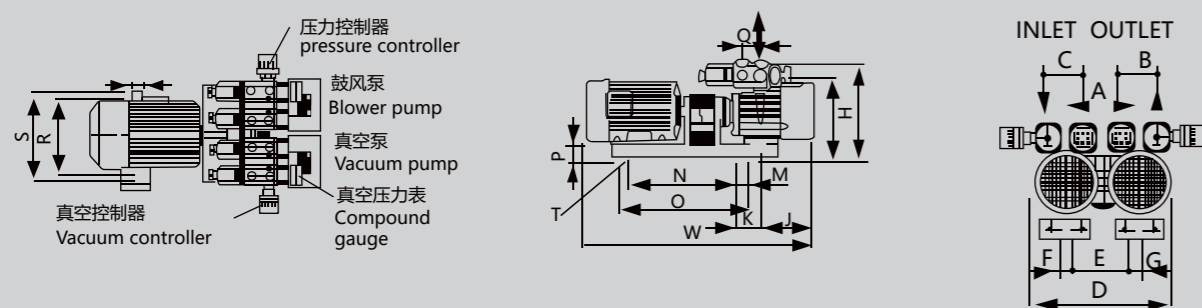

TYPE	H	D	W	A	B	C	E	F	G	I	J	K
PNK CRP 120	349	413	699	221	110	110	162	28	28	294	182	86

TYPE	L	M	N	O	P	Q	R	S	T
PNK CRP 120	30	46	330	416	50	50	270	298	4-Φ10

PNK CRP S25

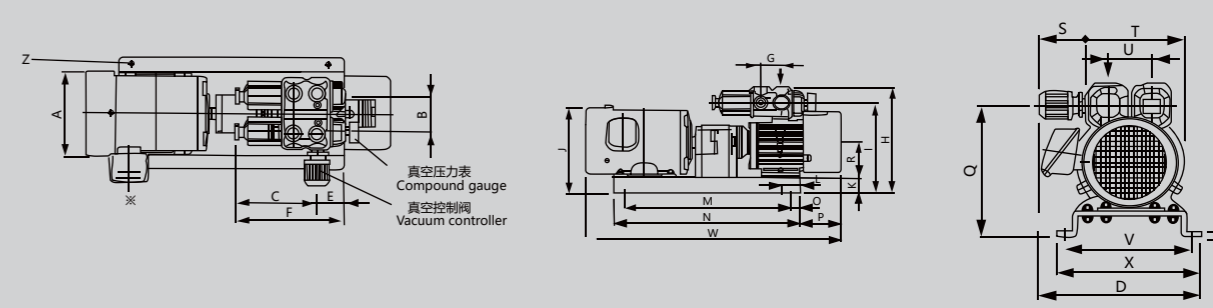

TYPE	H	D	W	A	B	C	E	F	G	I	J	K
PNK CRP S25	250	270	542(548)	Φ162 (Φ150)	80	135	42	177	92	210	193(187)	32

TYPE	L	M	N	O	P	Q	R	S	T	U	V	X	Y	Z
PNK CRP S25	45	340	402	31	83	212.5	80	78	154	90	205	230	4.5	4-Φ9

# 无油碳片真空泵

OIL FREE  
ROTARY VANE PUMPS

## 安装尺寸

### PNK CRP S40

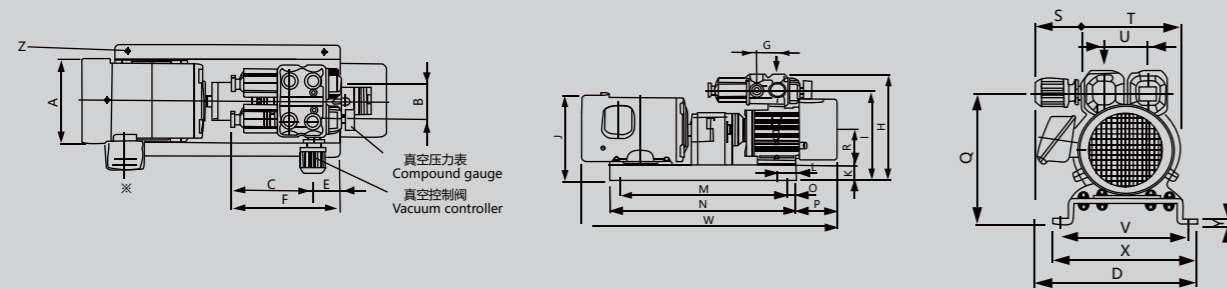

TYPE	H	D	W	A	B	C	E	F	G	I	J	K
PNK CRP S40	273	276	646	Φ186	80	173	54	227	92	233	222	38

TYPE	L	M	N	O	P	Q	R	S	T	U	V	X	Y	Z
PNK CRP S40	50	420	470	25	102	235.5	90	78	154	90	220	242	4.5	4-Φ9

### PNK CRP S60

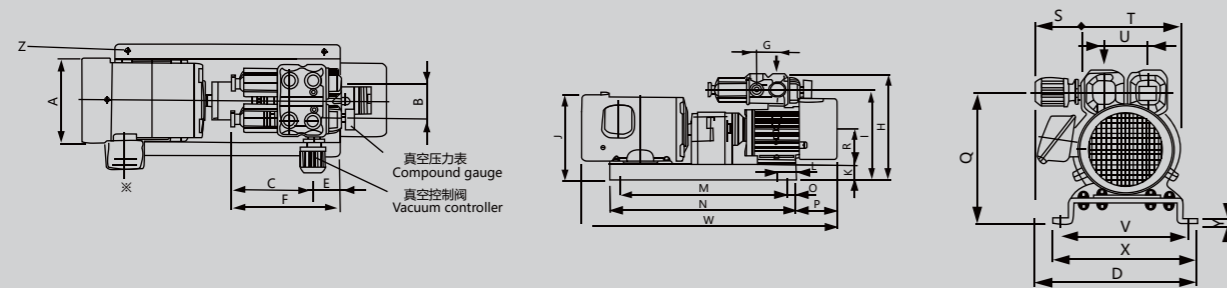

TYPE	H	D	W	A	B	C	E	F	G	I	J	K
PNK CRP S60	325	379	739	Φ207	100	197.5	24	221.5	70	270	241.5	38

TYPE	L	M	N	O	P	Q	R	S	T	U	V	X	Y	Z
PNK CRP S60	40	430	530	50	185.5	270	100	86	200	110	250	280	4.5	4-Φ12

# 无油活塞真空泵

洁净无油，真空极限好，适用范围广

OIL-FREE PISTON VACUUM PUMPS

PNK PP-V SERIES



## 特性和优点

PRONOTEK无油活塞真空泵是利用活塞来产生动力的一种真空/压力泵，无油设计，保养简单，可以抽真空或者提供压力差。由于其具备精密的构造，并运用现今先进的技术，因此其噪音量仅介于48.7-60.0dB，保持了实验室内的安静，避免实验操作者受到噪音的干扰。PNK PP系列活塞真空泵适合于生物、食品等行业对非腐蚀性环境使用所有真空泵只需要添加简单的转换套件，就可以将真空泵转换为压力泵，实现实验室一机多用的目的，轻松满足客户多种需要。

- 采用意大利生产工艺
- 元部件均源自意大利进口
- 超低噪音、体型轻巧
- 排水蒸气能力强
- 维护保养容易
- 能对应全压强领域的连续运转

## 应用领域

- 医疗健康（氧浓缩器、生化分析等）
- 食品、医药、化工（真空包装、气体置换）
- 半导体制造（吸附、搬运、安装等）
- 环境、节能（燃料电池等）
- 理化学（溶剂回收、真空干燥等）
- 分析（电子显微镜、质量分析等）

# 无油活塞真空泵

## OIL-FREE PISTON VACUUM PUMPS

### 规格参数

	Unit	PNK PP 200V	PNK PP 300V	PNK PP 400V
额定电压 Rated voltage/frequency	V/HZ	220v/50HZ/4uF	220v/50HZ/4uF	220v/50HZ/8uF
输出功率 Power input	W	≤120W, 0.5A	≤200W	≤250W
额定空气流量 Rated airflow	m <sup>3</sup> /h	1.8m <sup>3</sup> /h(30L/min)	2.4m <sup>3</sup> /h(40L/min)	3.6m <sup>3</sup> /h(60L/min)
最低真空度(负压) The minimum pressure(vacuum)	Kpa	-84(-640mmHg)	-86(-640mmHg)	-92(-700mmHg)
噪音 Sound	dB(A)	≤48dB(A)	≤48dB(A)	≤58dB(A)
使用环境温度 Ambient temperature	°C	5-40	5-40	5-40
绝缘等级 Insulation grade		B	B	B
冷态绝缘电阻 Cold insulation resistance	MΩ	≥100	≥100	≥100
耐电压强度 Voltage withstanding stress	min	1500V/50HZ(1min)	1500V/50HZ(1min)	1500V/50HZ(1min)
热保护器 Thermal protector	°C	自动复位130±5°C	自动复位130±5°C	自动复位130±5°C
重量 Weight	kg	1.8	3.5	5.5
安装尺寸 Installatong dimension	mm	L100*W74	L116*W108	L150*W112
外形尺寸 Overall dimension	mm	L143*W85*H121	L170*W124*H134	L188*W128*H186.3
重新启动压力 Restart preasure	kpa	0	0	0
进排气嘴外径 The inlet/outlet outer diameter	mm	Φ5	1/4-19FNPT管螺纹	1/4-19FNPT管螺纹

	Unit	PNK PP 550V	PNK PP 1400V	PNK PP 2000V
额定电压 Rated voltage/frequency	V/HZ	220v/50HZ/8uF	220v/50HZ/10uF	220v/50HZ/25uF
输出功率 Power input	W	≤320W	≤500W	≤550W
额定空气流量 Rated airflow	m <sup>3</sup> /h	5.5m <sup>3</sup> /h(92L/min)	7.2m <sup>3</sup> /h(120L/min)	12m <sup>3</sup> /h(200L/min)
最低真空度(负压) The minimum pressure(vacuum)	Kpa	-92(-700mmHg)	-92(-700mmHg)	-92(-700mmHg)
噪音 Sound	dB(A)	≤56dB(A)	≤58dB(A)	≤60dB(A)
使用环境温度 Ambient temperature	°C	5-40	5-40	5-40
绝缘等级 Insulation grade		B	B	B
冷态绝缘电阻 Cold insulation resistance	MΩ	≥100	≥100	≥100
耐电压强度 Voltage withstanding stress	min	1500V/50HZ(1min)	1500V/50HZ(1min)	1500V/50HZ(1min)
热保护器 Thermal protector	°C	自动复位130±5°C	自动复位130±5°C	自动复位130±5°C
重量 Weight	kg	6.0	8.0	10
安装尺寸 Installatong dimension	mm	L147*W83	L203*W112	L204*W112
外形尺寸 Overall dimension	mm	L237*W97*H162	L244*W128*H186	L224*W128*H205
重新启动压力 Restart preasure	kpa	0	0	0
进排气嘴外径 The inlet/outlet outer diameter	mm	1/4-18FNPT管螺纹	1/4-18FNPT管螺纹	3/8-18FNPT管螺纹

# 无油活塞真空泵

OIL-FREE  
PISTON VACUUM PUMPS

## 规格参数

	Unit	PNK PP 2400V	PNK PP 3000V
额定电压 Rated voltage/frequency	V/HZ	220v/50HZ	220v/50HZ
输出功率 Power input	W	≤900W	≤1100W
额定空气流量 Rated airflow	m <sup>3</sup> /h	13.2m <sup>3</sup> /h(220L/min)	16.8m <sup>3</sup> /h(280L/min)
最低真空度(负压) The minimum pressure(vacuum)	Kpa	-94	-94
噪音 Sound	dB(A)	≤75dB(A)	≤76dB(A)
使用环境温度 Ambient temperature	°C	5-40	5-40
绝缘等级 Insulation grade		B	B
冷态绝缘电阻 Cold insulation resistance	MΩ	≥100	≥100
耐电压强度 Voltage withstanding stress	min	1500V/50HZ(1min)	1500V/50HZ(1min)
热保护器 Thermal protector	°C	自动复位130±5°C	自动复位130±5°C
重量 Weight	kg	17	17.5
安装尺寸 Installatong dimension	mm	L246*W127	L246*W127
外形尺寸 Overall dimension	mm	L325*W153*H280	L325*W153*H280
重新启动压力 Restart preasure	kpa	0	0
进排气嘴外径 The inlet/outlet outer diameter	mm	1/2-19FNPT管螺纹	1/2-19FNPT管螺纹

# 无油活塞真空泵

OIL-FREE  
PISTON VACUUM PUMPS

## 性能曲线

PNK PP 200V

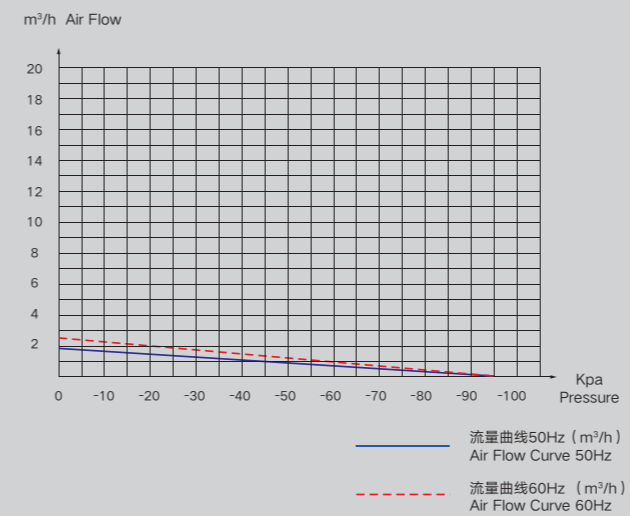

PNK PP 300V

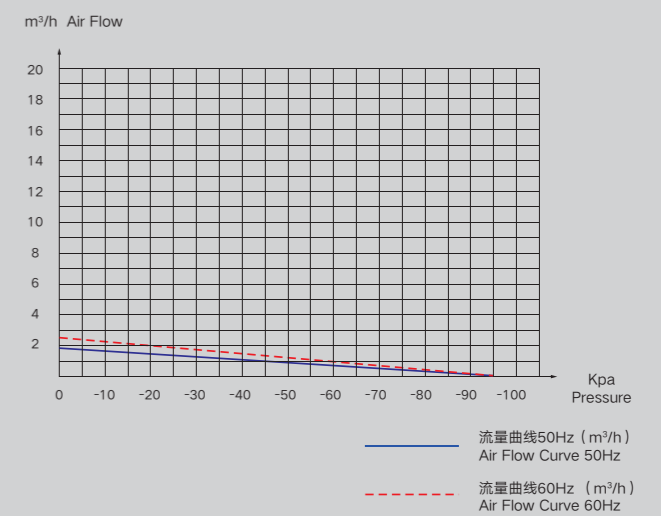

PNK PP 400V

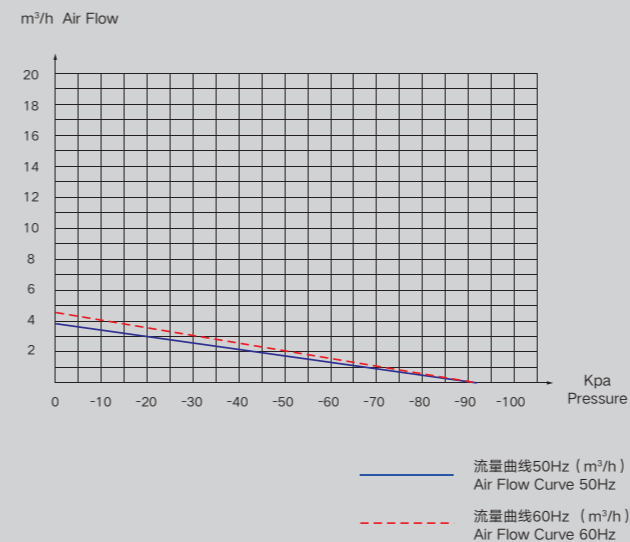

PNK PP 550V

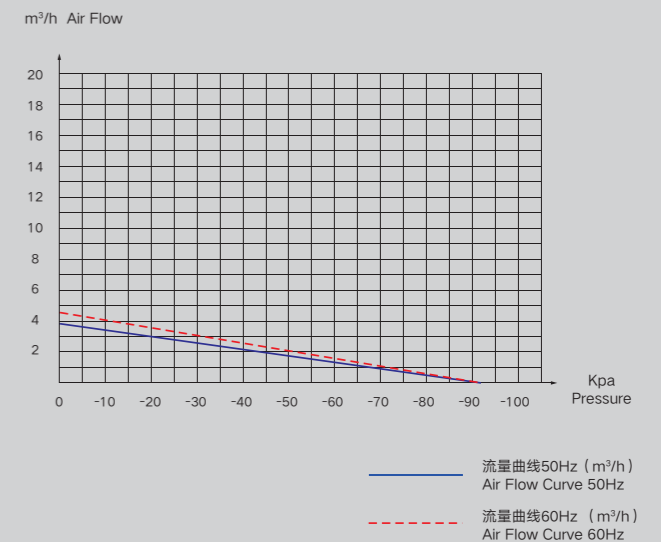

# 无油活塞真空泵

OIL-FREE  
PISTON VACUUM PUMPS

性能曲线

PNK PP 1400V

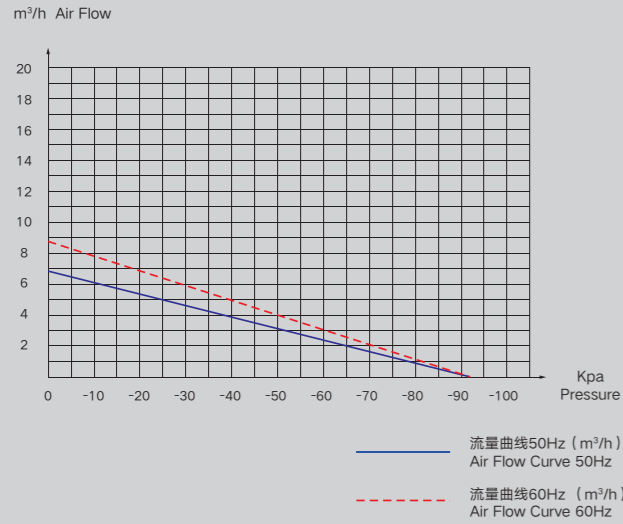

PNK PP 2000V

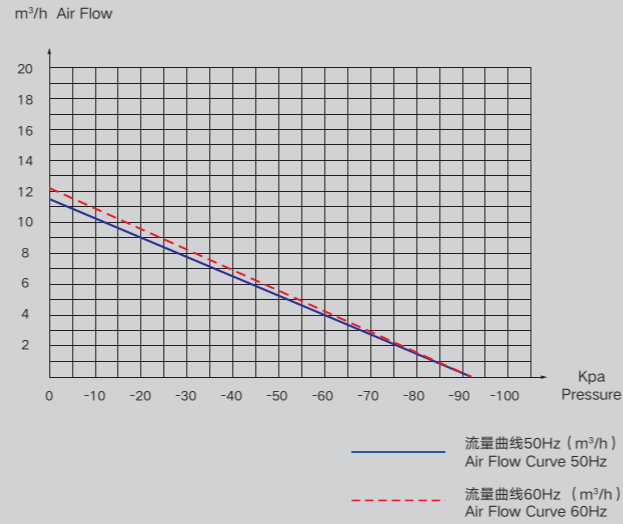

PNK PP 2400V

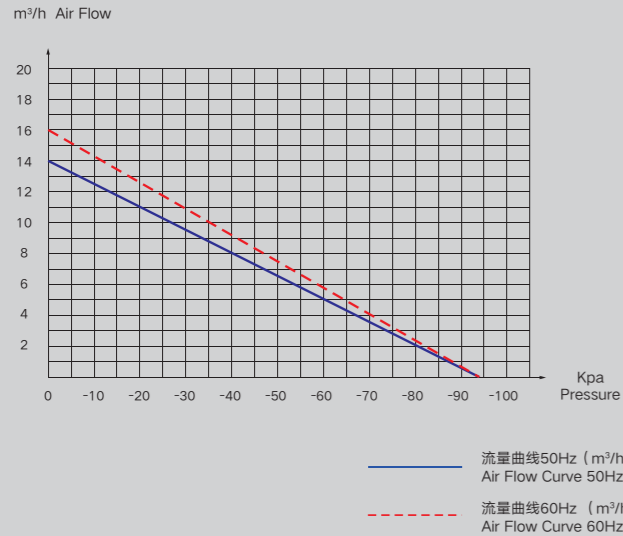

PNK PP 3000V

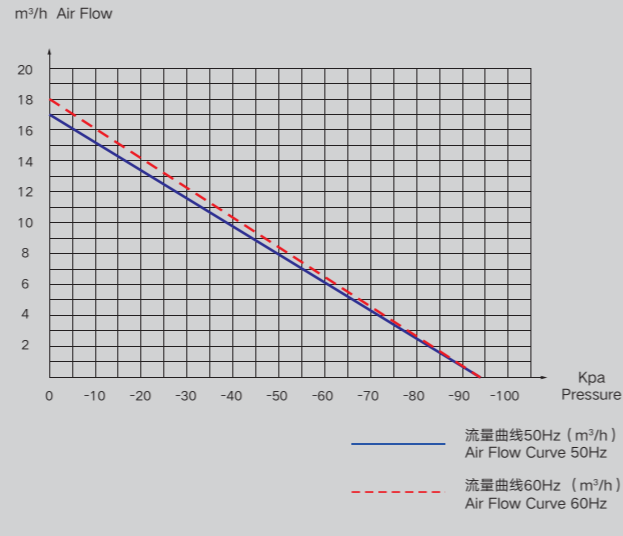

# 无油活塞真空泵

OIL-FREE  
PISTON VACUUM PUMPS

安装尺寸

PNK PP 200V

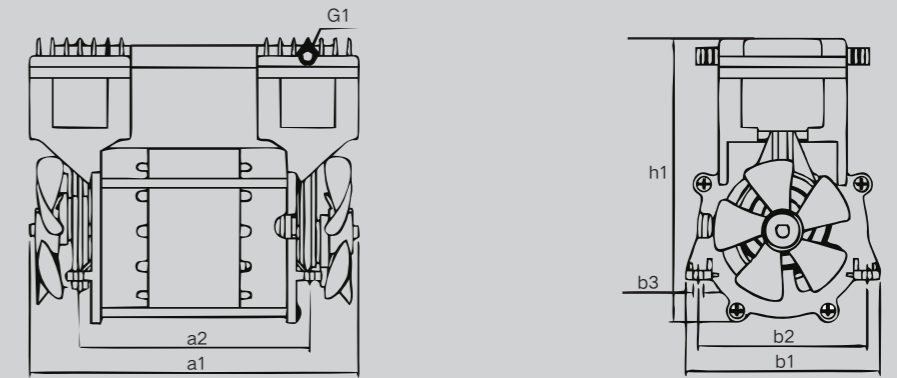

TYPE	a1	a2	b1	b2	b3	h1	G1
PNK PP 200V	143	100	100	74	5	121	5

PNK PP 300V

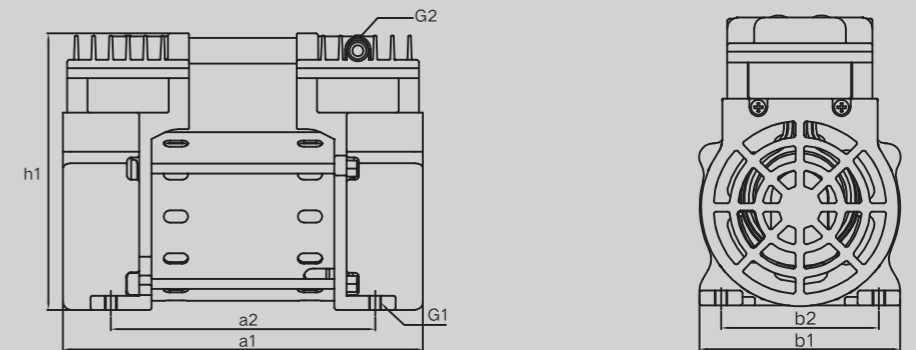

TYPE	a1	a2	b1	b2	G1	G2	h1
PNK PP 300V	177	130	94	74	M6*1.0	1/8-28PT	136

# 无油活塞真空泵

## OIL-FREE PISTON VACUUM PUMPS

### 安装尺寸

PNK PP 400V

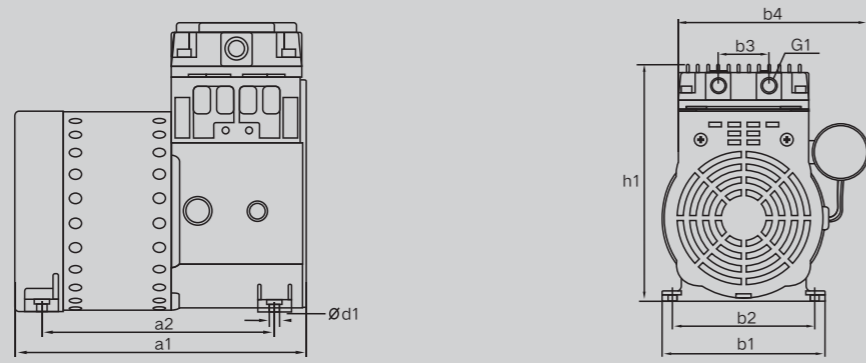

TYPE	a1	a2	b1	b2	b3	b4	d1	h1	G1
PNK PP 400V	194	153	124	95	95	146	7	186	1/4-19PT

PNK PP 1400V

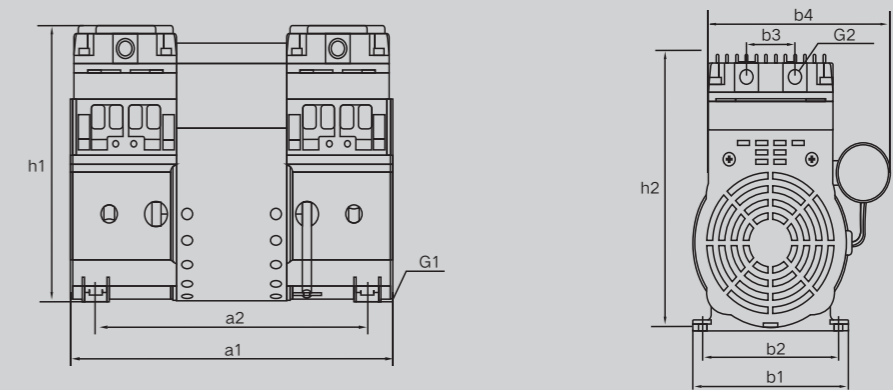

TYPE	a1	a2	b1	b2	b3	b4	h1	h2	G1	G2
PNK PP 1400V	244	203	128	112	40	146	186.3	186.3	7	1/4-19PT

PNK PP 550V

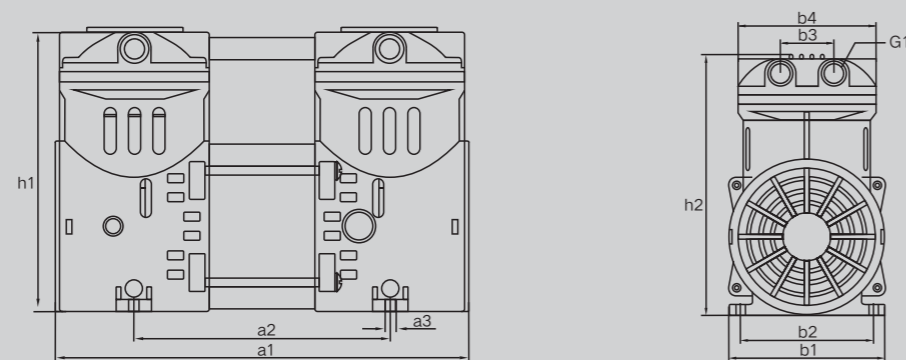

TYPE	a1	a2	a3	b1	b2	b3	b4	h1	h2	G1
PNK PP 550V	237	147	6	97	83	33	86	186.3	162	1/4-19PT

PNK PP 2000V

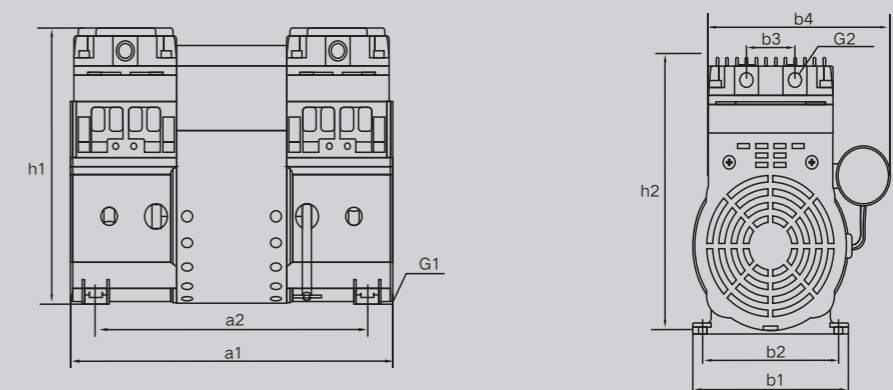

TYPE	a1	a2	b1	b2	b3	b4	h1	h2	G1	G2
PNK PP 2000V	244	203	128	112	40	146	205	205	7	3/8-19PT

# 无油活塞真空泵

OIL-FREE  
PISTON VACUUM PUMPS

安装尺寸

# 无油活塞真空泵

洁净无油，真空极限好，适用范围广

OIL-FREE PISTON VACUUM PUMPS  
PNK PP-H SERIES

PNK PP 2400V

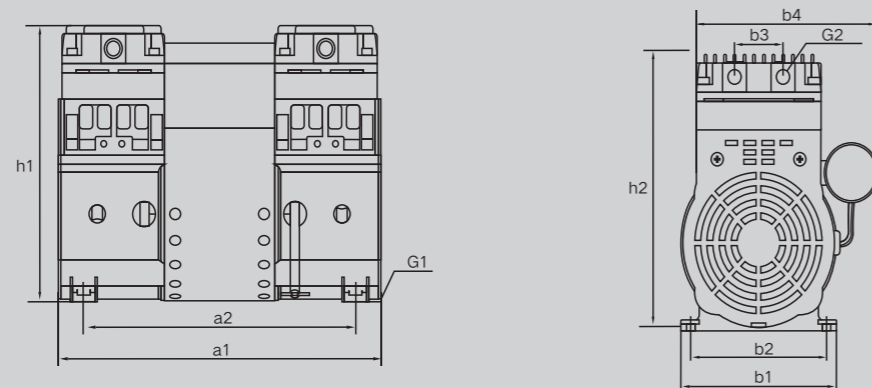

TYPE	a1	a2	b1	b2	b3	b4	h1	h2	G1	G2
PNK PP 2400V	325	246	153	127	60	170	280	270	7	3/8-19PT

PNK PP 3000V

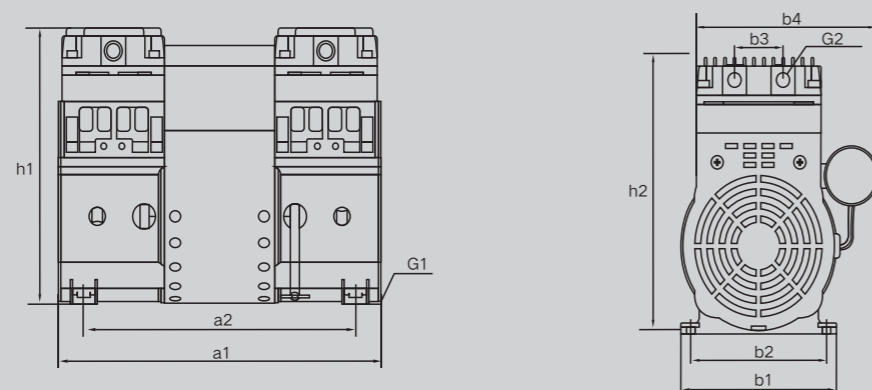

TYPE	a1	a2	b1	b2	b3	b4	h1	h2	G1	G2
PNK PP 3000V	325	245	153	127	60	170	280	270	7	3/8-19PT





# 无油活塞真空泵

洁净无油，真空极限好，适用范围广

OIL-FREE PISTON VACUUM PUMPS

PNK PP-H SERIES

## 特性和优点

PRONOTEK无油活塞真空泵是利用活塞来产生动力的一种真空/压力泵，无油设计，保养简单，可以抽真空或者提供压力差。由于其具备精密的构造，并运用现今先进的技术，因此其噪音量仅介于48.7-60.0dB，保持了实验室内的安静，避免实验操作者受到噪音的干扰。PNK PP系列活塞真空泵适合于生物、食品等行业对非腐蚀性环境使用所有真空泵只需要添加简单的转换套件，就可以将真空泵转换为压力泵，实现实验室一机多用的目的，轻松满足客户多种需要。

- 采用意大利生产工艺
- 元部件均源自意大利进口
- 超低噪音、体型轻巧
- 排水蒸气能力强
- 维护保养容易
- 能对应全压强领域的连续运转

## 应用领域

- 医疗健康（氧浓缩器、生化分析等）
- 食品、医药、化工（真空包装、气体置换）
- 半导体制造（吸附、搬运、安装等）
- 环境、节能（燃料电池等）
- 理化学（溶剂回收、真空干燥等）
- 分析（电子显微镜、质量分析等）

# 无油活塞真空泵

OIL-FREE

PISTON VACUUM PUMPS

## 规格参数

	Unit	PNK PP 550H	PNK PP 1400H	PNK PP 2000H
额定电压 Rated voltage/frequency	V/HZ	220v/50HZ/8uF	220v/50HZ/10uF	220v/50HZ/25uF
输出功率 Power input	W	≤320W	≤450W	≤550W
额定空气流量 Rated airflow	m <sup>3</sup> /h	4.1m <sup>3</sup> /h(68L/min)	6.0m <sup>3</sup> /h(100L/min)	10m <sup>3</sup> /h(166L/min)
最低真空度(负压) The minimum pressure(vacuum)	Kpa	-98(-740mmHg)	-98(-740mmHg)	-98(-740mmHg)
噪音 Sound	dB(A)	≤56dB(A)	≤58dB(A)	≤60dB(A)
使用环境温度 Ambient temperature	°C	5-40	5-40	5-40
绝缘等级 Insulation grade		B	B	B
冷态绝缘电阻 Cold insulation resistance	MΩ	≥100	≥100	≥100
耐压强度 Voltage withstanding stress	min	1500V/50HZ(1min)	1500V/50HZ(1min)	1500V/50HZ(1min)
热保护器 Thermal protector	°C	自动复位130±5°C	自动复位130±5°C	自动复位130±5°C
重量 Weight	kg	6.0	8.5	9.0
安装尺寸 Installatong dimension	mm	L147*W83	L203*W112	L204*W112
外形尺寸 Overall dimension	mm	L237*W97*H162	L244*W128*H186	L224*W128*H205
重新启动压力 Restart preasure	kpa	0	0	0
进排气嘴外径 The inlet/outlet outer diameter	mm	1/4-18FNPT管螺纹	1/4-18FNPT管螺纹	3/8-18FNPT管螺纹

# 无油活塞真空泵

OIL-FREE  
PISTON VACUUM PUMPS

## 规格参数

	Unit	PNK PP 2400H	PNK PP 3000H
额定电压 Rated voltage/frequency	V/HZ	220v/50HZ	220v/50HZ
输出功率 Power input	W	≤900W	≤1100W
额定空气流量 Rated airflow	m <sup>3</sup> /h	13.2m <sup>3</sup> /h(220L/min)	16.8m <sup>3</sup> /h(280L/min)
最低真空度(负压) The minimum pressure(vacuum)	Kpa	-98	-98
噪音 Sound	dB(A)	≤75dB(A)	≤76dB(A)
使用环境温度 Ambient temperature	°C	5-40	5-40
绝缘等级 Insulation grade		B	B
冷态绝缘电阻 Cold insulation resistance	MΩ	≥100	≥100
耐电压强度 Voltage withstanding stress	min	1500V/50HZ(1min)	1500V/50HZ(1min)
热保护器 Thermal protector	°C	自动复位130±5°C	自动复位130±5°C
重量 Weight	kg	17	17.5
安装尺寸 Installatong dimension	mm	L246*W127	L246*W127
外形尺寸 Overall dimension	mm	L325*W153*H280	L325*W153*H280
重新启动压力 Restart preasure	kpa	0	0
进排气嘴外径 The inlet/outlet outer diameter	mm	1/2-19FNPT管螺纹	1/2-19FNPT管螺纹

# 无油活塞真空泵

OIL-FREE  
PISTON VACUUM PUMPS

## 性能曲线

PNK PP 550H

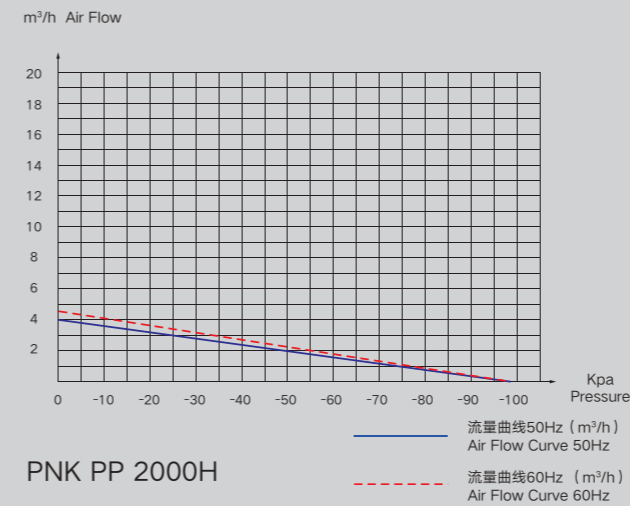

PNK PP 1400H

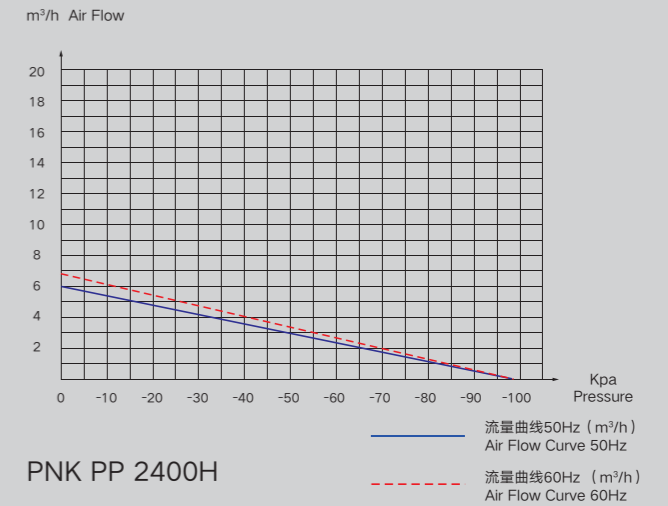

PNK PP 2000H

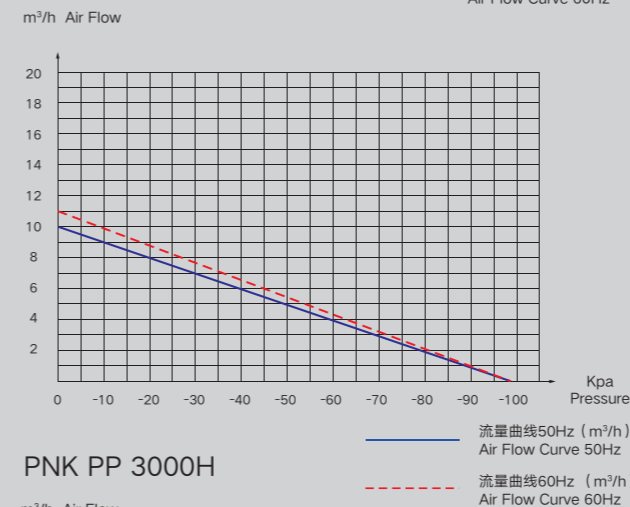

PNK PP 2400H

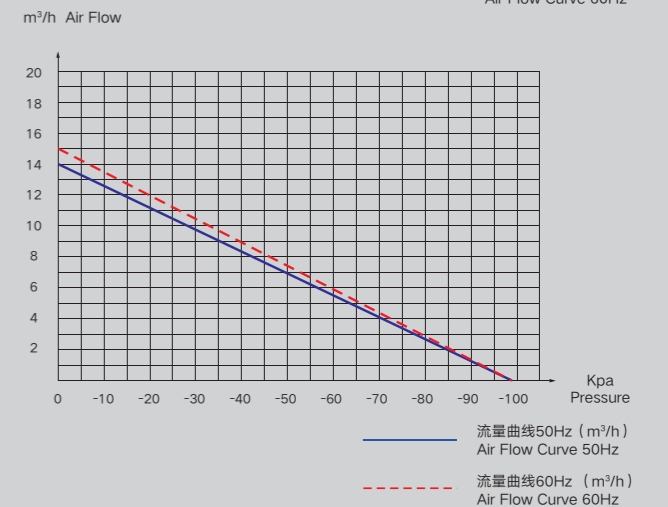

PNK PP 3000H

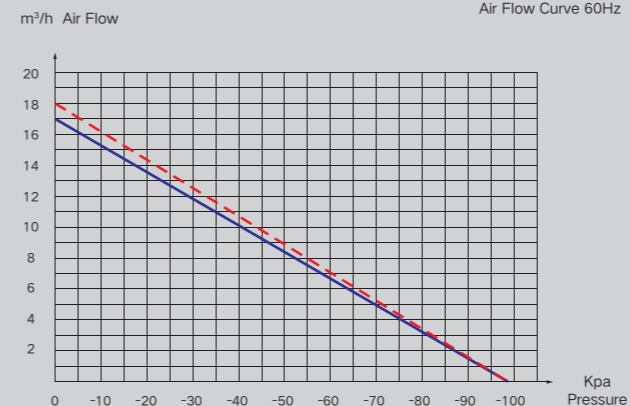

# 无油活塞真空泵

## OIL-FREE PISTON VACUUM PUMPS

### 安装尺寸

PNK PP 550H

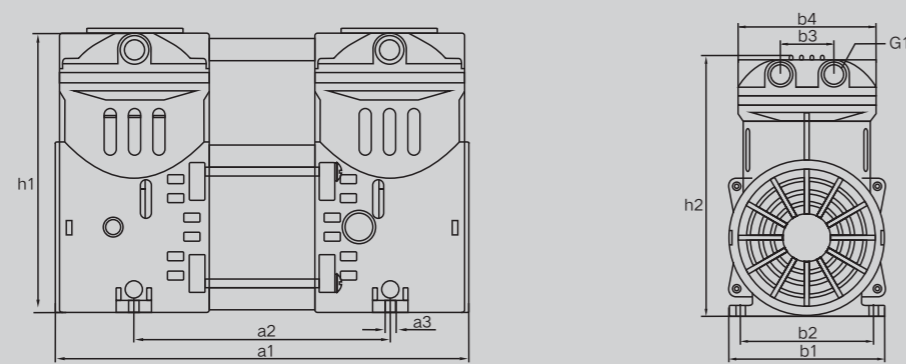

TYPE	a1	a2	a3	b1	b2	b3	b4	h1	h2	G1
PNK PP 550H	237	147	6	97	83	33	86	186.3	162	1/4-19PT

PNK PP 2000H

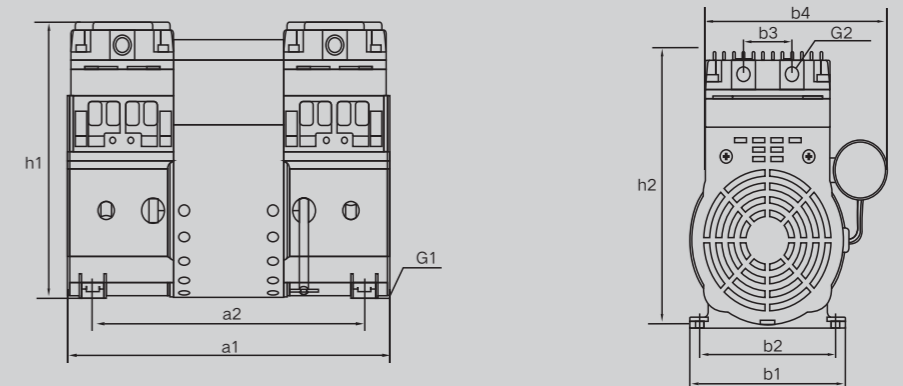

TYPE	a1	a2	b1	b2	b3	b4	h1	h2	G1	G2
PNK PP 2000H	244	203	128	112	40	146	205	205	7	3/8-19PT

PNK PP 1400H

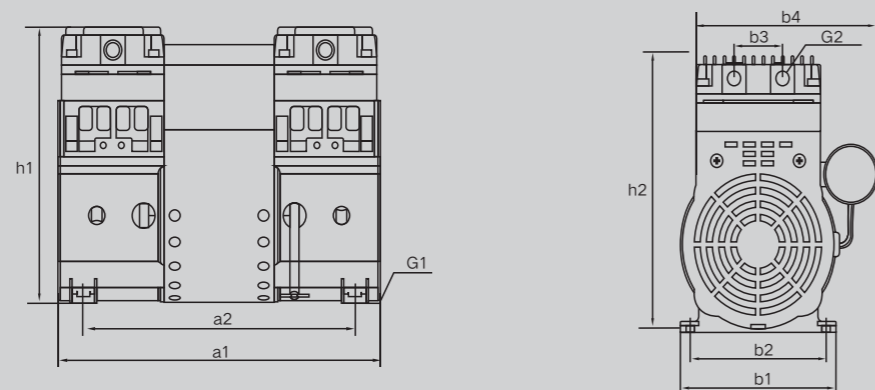

TYPE	a1	a2	b1	b2	b3	b4	h1	h2	G1	G2
PNK PP 1400H	244	203	128	112	40	146	186.3	186.3	7	1/4-19PT

PNK PP 2000H

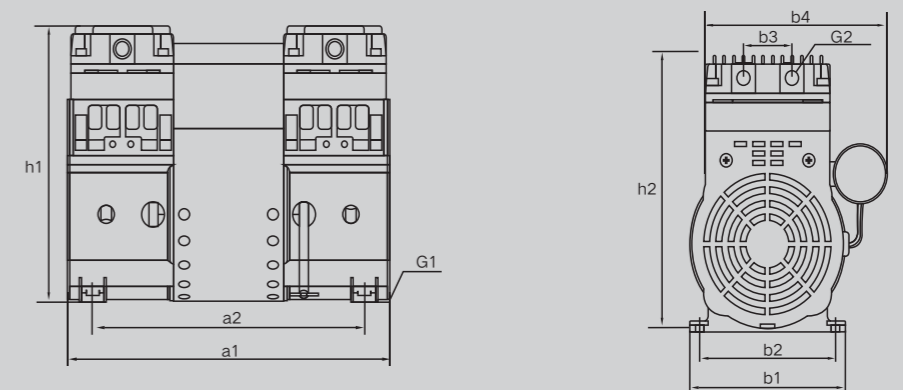

TYPE	a1	a2	b1	b2	b3	b4	h1	h2	G1	G2
PNK PP 2000H	244	203	128	112	40	146	205	205	7	3/8-19PT

# 无油活塞真空泵

OIL-FREE  
PISTON VACUUM PUMPS

安装尺寸

PNK PP 3000H

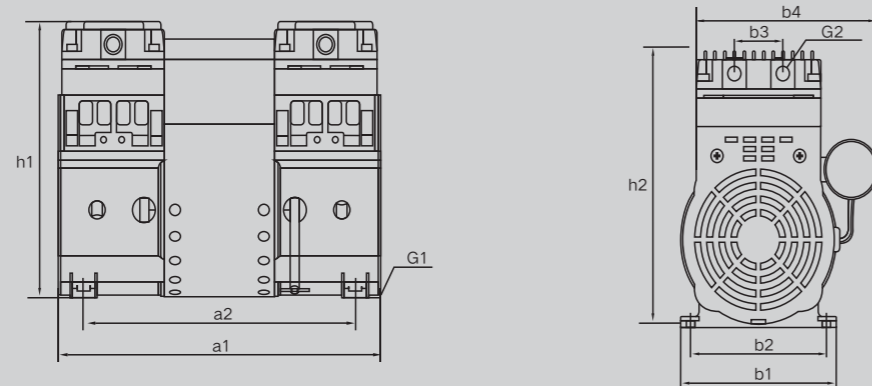

TYPE	a1	a2	b1	b2	b3	b4	h1	h2	G1	G2
PNK PP 3000H	325	245	153	127	60	170	280	270	7	3/8-19PT

# 无油活塞真空泵

洁净无油，真空极限好，适用范围广

OIL-FREE PISTON VACUUM PUMPS  
PNK PP-C SERIES



# 无油活塞真空泵

## OIL-FREE PISTON VACUUM PUMPS

### 规格参数

	Unit	PNK PP 200C	PNK PP 300C	PNK PP 550C
额定电压 Rated voltage/frequency	V/HZ	220v/50HZ/4uF	220v/50HZ/4uF	220v/50HZ/8uF
输出功率 Power input	W	≤120W, 0.6A	≤200W	≤320W
额定空气流量 Rated airflow	m <sup>3</sup> /h	1.3m <sup>3</sup> /h(22L/min)	1.5m <sup>3</sup> /h(25L/min)	3.3m <sup>3</sup> /h(55L/min)
额定工作压力 Rating working pressure	Kpa	100	150	207
最大工作压力 Maximum working pressure	Kpa	200	400	600
噪音 Sound	dB(A)	≤48dB(A)	≤50dB(A)	≤58dB(A)
使用环境温度 Ambient temperature	°C	5-40	5-40	5-40
绝缘等级 Insulation grade		B	B	B
冷态绝缘电阻 Cold insulation resistance	MΩ	≥100	≥100	≥100
耐电压强度 Voltage withstanding stress	min	1500V/50HZ(1min)	1500V/50HZ(1min)	1500V/50HZ(1min)
热保护器 Thermal protector	°C	自动复位130±5°C	自动复位130±5°C	自动复位130±5°C
重量 Weight	kg	1.8	3.5	6.0
安装尺寸 Installatong dimension	mm	L100*W74	L116*W108	L147*W83
外形尺寸 Overall dimension	mm	L143*W85*H121	L170*W124*H134	L237*W97*H162
重新启动压力 Restart preasure	kpa	0	0	0
进排气嘴外径 The inlet/outlet outer diameter	mm	Φ5	1/4-18FNPT管螺纹	1/4-18FNPT管螺纹

	Unit	PNK PP 1400C	PNK PP 2000C	PNK PP 2400C
额定电压 Rated voltage/frequency	V/HZ	220v/50HZ/10uF	220v/50HZ/25uF	220v/50HZ
输出功率 Power input	W	≤500W	≤600W	≤1100W
额定空气流量 Rated airflow	m <sup>3</sup> /h	6.6m <sup>3</sup> /h(110L/min)	8.8m <sup>3</sup> /h(146L/min)	14.4m <sup>3</sup> /h(240L/min)
额定工作压力 Rating working pressure	Kpa	207	300	360
最大工作压力 Maximum working pressure	Kpa	600-700	800	900
噪音 Sound	dB(A)	≤58dB(A)	≤60dB(A)	≤75dB(A)
使用环境温度 Ambient temperature	°C	5-40	5-40	5-40
绝缘等级 Insulation grade		B	B	B
冷态绝缘电阻 Cold insulation resistance	MΩ	≥100	≥100	≥100
耐电压强度 Voltage withstanding stress	min	1500V/50HZ(1min)	1500V/50HZ(1min)	1500V/50HZ(1min)
热保护器 Thermal protector	°C	自动复位130±5°C	自动复位130±5°C	自动复位130±5°C
重量 Weight	kg	8.0	10	17
安装尺寸 Installatong dimension	mm	L203*W112	L204*W112	L246*W127
外形尺寸 Overall dimension	mm	L244*W128*H186	L224*W128*H205	L325*W153*H280
重新启动压力 Restart preasure	kpa	0	0	0
进排气嘴外径 The inlet/outlet outer diameter	mm	1/4-18FNPT管螺纹	3/8-18FNPT管螺纹	1/2-19FNPT管螺纹

# 无油活塞真空泵

OIL-FREE  
PISTON VACUUM PUMPS

## 规格参数

	Unit	PNK PP 3000C
额定电压 Rated voltage/frequency	V/HZ	220v/50HZ
输出功率 Power input	W	≤1500W
额定空气流量 Rated airflow	m <sup>3</sup> /h	16.8m <sup>3</sup> /h(280L/min)
额定工作压力 Rating working pressure	Kpa	450
最大工作压力 Maximum working pressure	Kpa	1000
噪音 Sound	dB(A)	≤76dB(A)
使用环境温度 Ambient temperature	°C	5-40
绝缘等级 Insulation grade		B
冷态绝缘电阻 Cold insulation resistance	MΩ	≥100
耐电压强度 Voltage withstanding stress	min	1500V/50HZ(1min)
热保护器 Thermal protector	°C	自动复位130±5°C
重量 Weight	kg	17.5
安装尺寸 Installatong dimension	mm	L246*W127
外形尺寸 Overall dimension	mm	L325*W153*H280
重新启动压力 Restart preasure	kpa	0
进排气嘴外径 The inlet/outlet outer diameter	mm	1/2-19FNPT管螺纹

# 无油活塞真空泵

OIL-FREE  
PISTON VACUUM PUMPS

## 性能曲线

PNK PP 200C

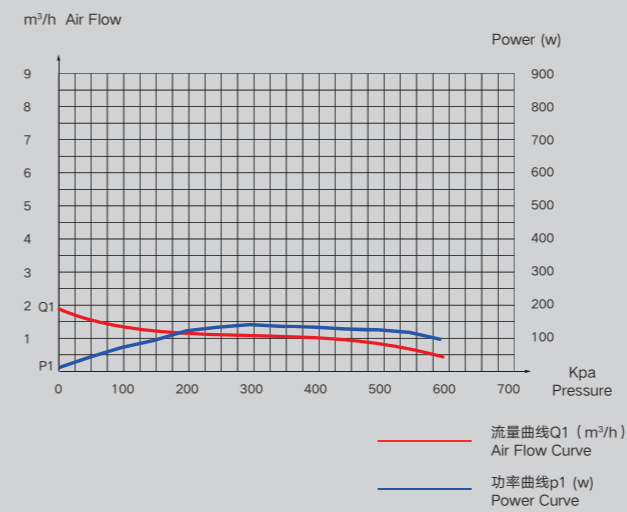

PNK PP 300C

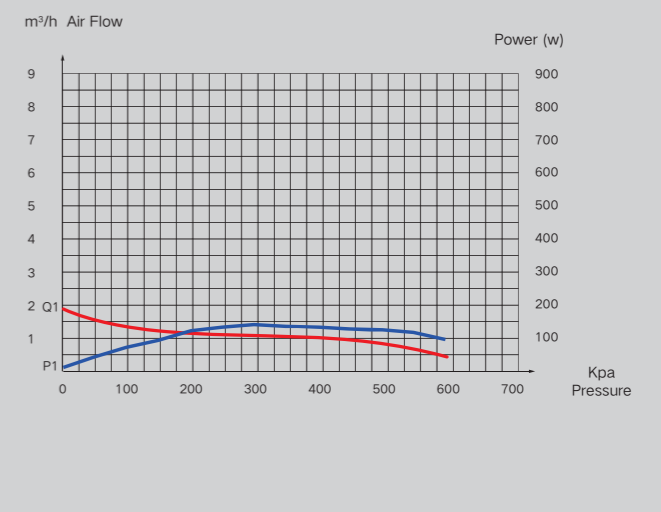

PNK PP 550C

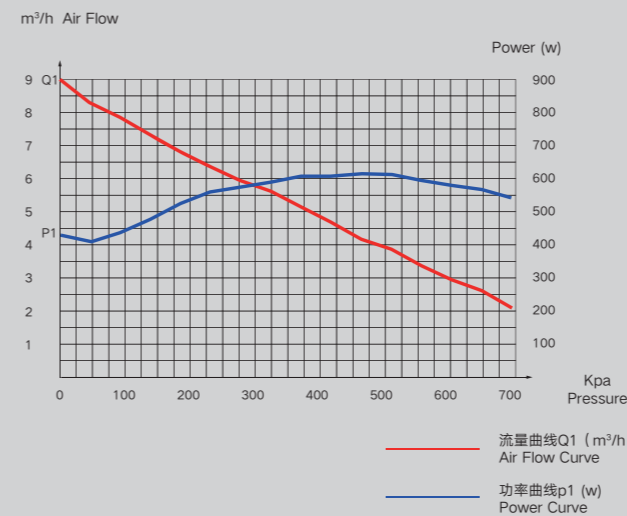

PNK PP 1400C

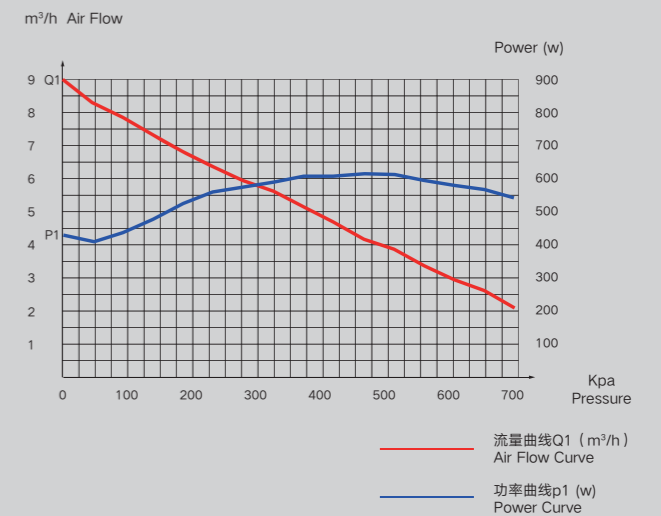

# 无油活塞真空泵

OIL-FREE  
PISTON VACUUM PUMPS

性能曲线

PNK PP 2000C

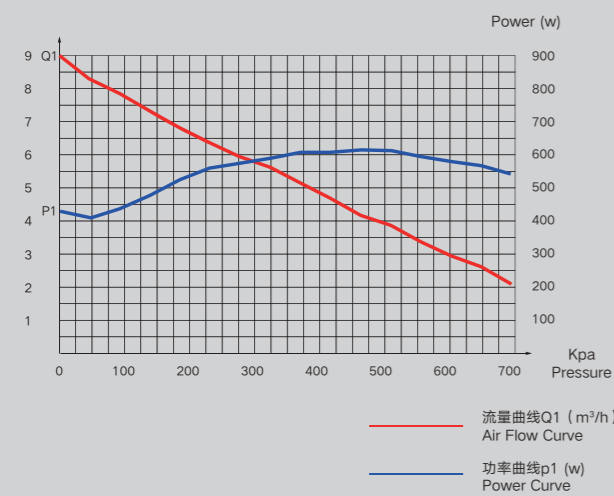

PNK PP 2400C

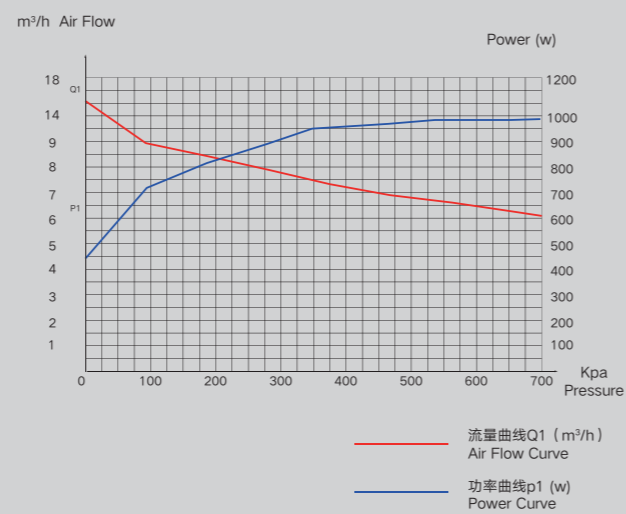

PNK PP 3000C

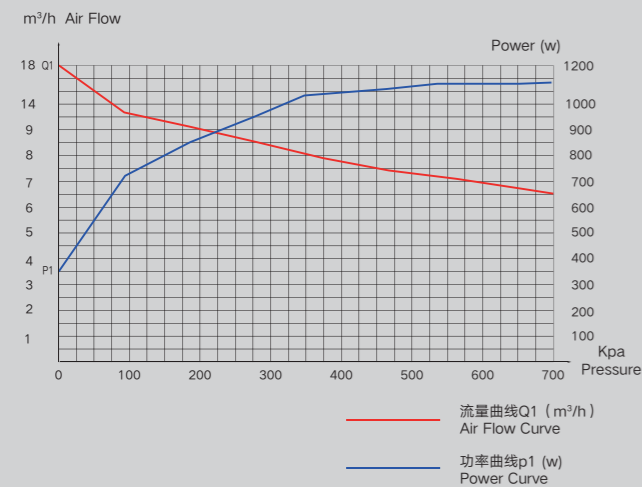

# 无油活塞真空泵

OIL-FREE  
PISTON VACUUM PUMPS

安装尺寸

PNK PP 200C

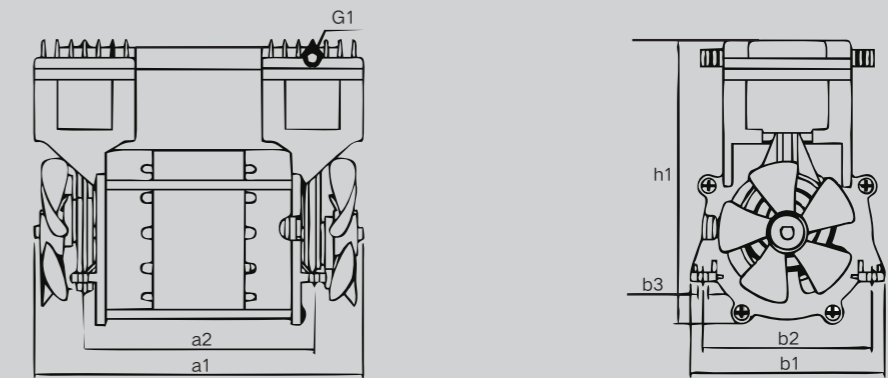

TYPE	a1	a2	b1	b2	b3	h1	G1
PNK PP 200C	143	100	100	74	5	121	5

PNK PP 300C

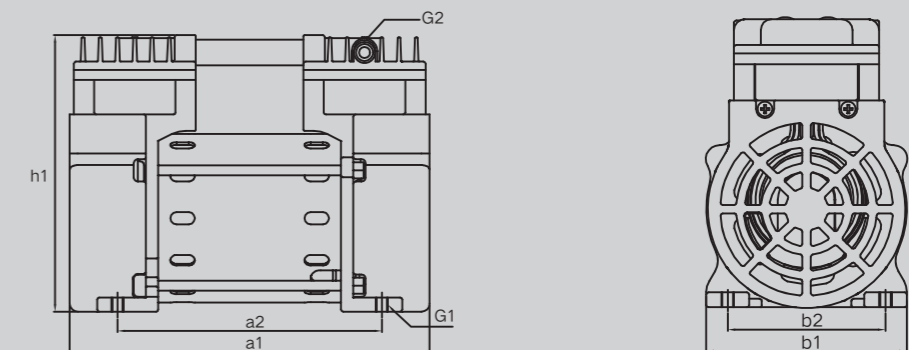

TYPE	a1	a2	b1	b2	G1	G2	h1
PNK PP 300C	177	130	94	74	M6*1.0	1/8-28PT	136

# 无油活塞真空泵

## OIL-FREE PISTON VACUUM PUMPS

### 安装尺寸

PNK PP 550C

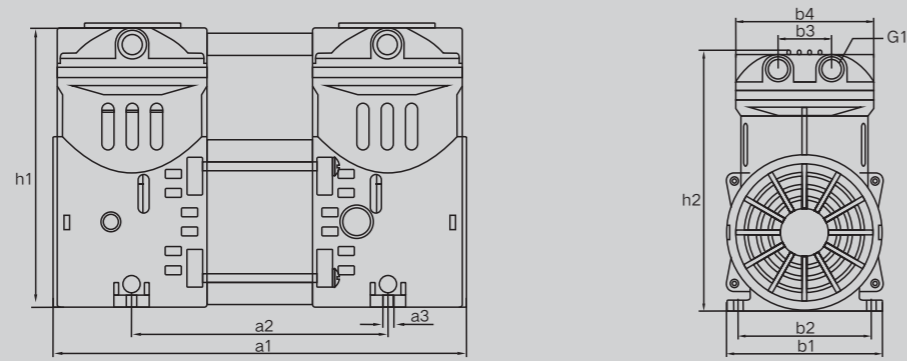

TYPE	a1	a2	a3	b1	b2	b3	b4	h1	h2	G1
PNK PP 550C	237	147	6	97	83	33	86	186.3	162	1/4-19PT

PNK PP 2000C

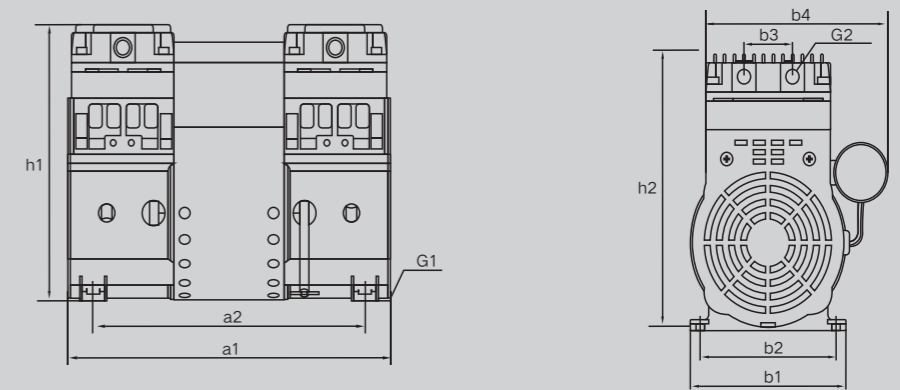

TYPE	a1	a2	b1	b2	b3	b4	h1	h2	G1	G2
PNK PP 2000C	244	203	128	112	40	146	205	205	7	3/8-19PT

PNK PP 1400C

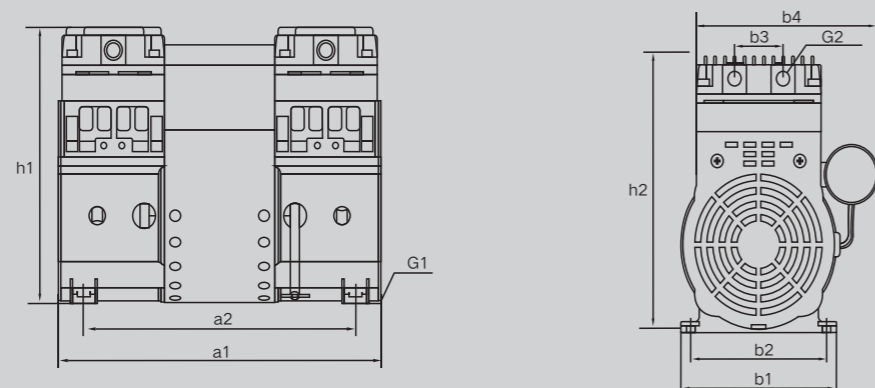

TYPE	a1	a2	b1	b2	b3	b4	h1	h2	G1	G2
PNK PP 1400C	244	203	128	112	40	146	186.3	186.3	7	1/4-19PT

PNK PP 2400C

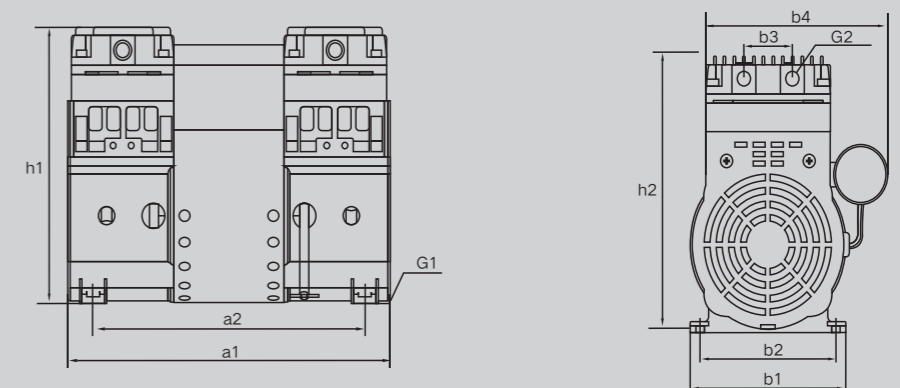

TYPE	a1	a2	b1	b2	b3	b4	h1	h2	G1	G2
PNK PP 2400C	325	246	153	127	60	170	280	270	7	3/8-19PT



# 无油活塞真空泵

OIL-FREE  
PISTON VACUUM PUMPS

安装尺寸

PNK PP 3000C

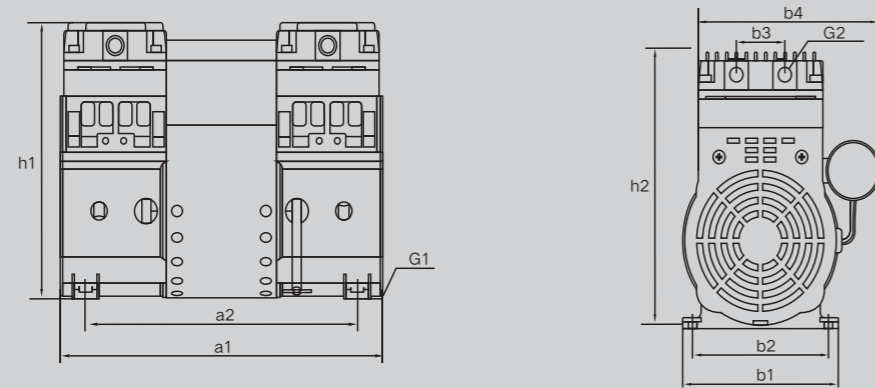

TYPE	a1	a2	b1	b2	b3	b4	h1	h2	G1	G2
PNK PP 3000C	325	245	153	127	60	170	280	270	7	3/8-19PT